

User's Guide

Publication number E3453-97008
October 2002

© Copyright Agilent Technologies, Inc. 1994-2002
All Rights Reserved

For Safety and Regulatory information,
see the pages behind the index.



Agilent Technologies

Emulation for the Motorola MPC82XX

Agilent Technologies E5900B Option 100 Emulation Probe—At a Glance

This manual describes how to set up:

- an emulation probe
- an emulation module
- an emulation migration

The emulation probe provides a low-cost way to debug embedded software for Motorola MPC82XX family microprocessors. The emulation probe lets you use the target processor's built-in debugging features, including: run control, register access, and memory access. A high-level source debugger can use the emulation probe to debug code running on the target system.

The emulation probe can be controlled by a debugger on a host computer or by the Emulation Control Interface on an Agilent 16700-series logic analysis system. The emulation probe communicates with a host computer or logic analysis system via LAN.

E5900B Emulation Probe

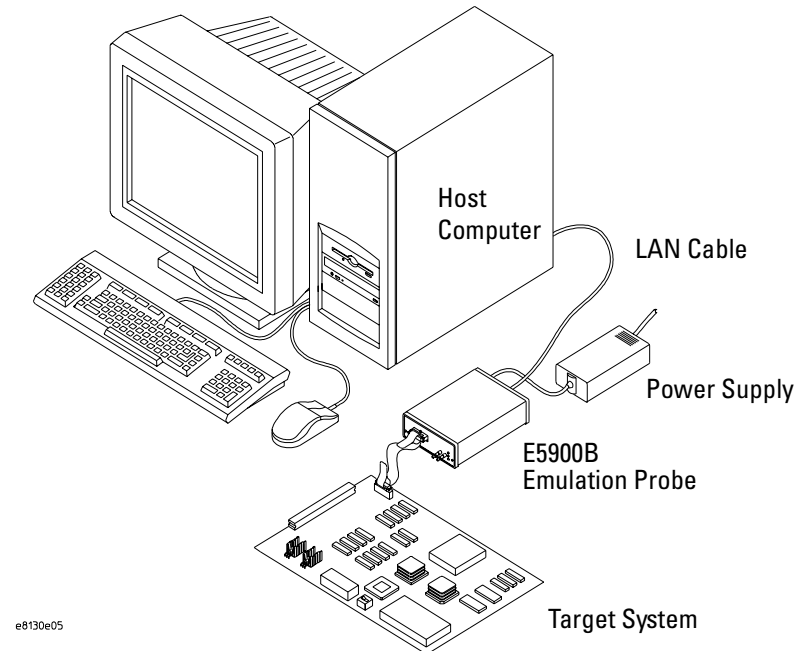

e8130e05

E5901B Emulation Module Kit

The Agilent E5901B emulation module kit includes the E5900B emulation probe, the E5901B emulation module, and other items listed on page 18. The Agilent E5901B emulation module plugs into your Agilent 16700-series logic analysis system frame. It provides power, cross triggering, and limited communication for the E5900B emulation probe through the module/probe interconnect cable. The logic analysis system communicates with the target system through the LAN connection to the E5900B emulation probe.

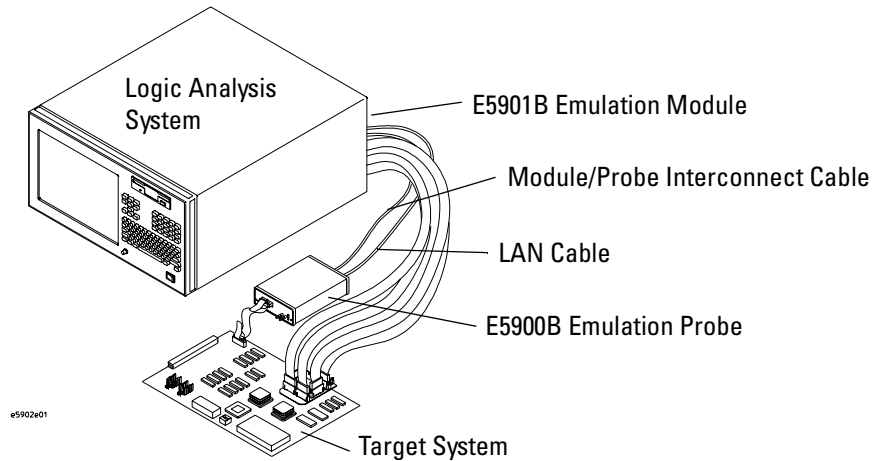

E5902B Emulation Migration Kit

The emulation migration includes the parts needed to use an emulation probe for a new processor family.

In This Book

This book documents the following products:

Emulation Probe

Processors supported	Product ordered	Includes
MPC8240 MPC8260	Agilent Technologies	E5900B emulation probe, cables, software, and
MPC8241 MPC8264	E5900B Option #100	manual
MPC8245 MPC8265		
MPC8255 MPC8266		

Emulation Module

Processors supported	Product ordered	Includes
MPC8240 MPC8260	E5901B Option #100	E5901B emulation module, E5900B Option #100
MPC8241 MPC8264		emulation probe, cables, software, and manual
MPC8245 MPC8265		
MPC8255 MPC8266		

Emulation Migration

Processors supported	Product ordered	Includes
MPC8240 MPC8260	E5902B Option #100	Target board adapter, front panel, tool kit, cables,
MPC8241 MPC8264		software, and manual
MPC8245 MPC8265		
MPC8255 MPC8266		

Contents

Agilent Technologies E5900B Option 100 Emulation Probe— At a Glance	2
E5900B Emulation Probe	2
E5901B Emulation Module Kit	3
E5902B Emulation Migration Kit	3
In This Book	4

1 Overview 13

Setup Flowchart	15
Agilent E5900B Emulation Probe	16
Equipment supplied	16
Minimum equipment required	16
Agilent E5901B Emulation Module Kit	18
Equipment supplied	18
Minimum equipment required	18
Agilent E5902B Emulation Migration Kit	20
Equipment supplied	20
Minimum equipment required	20



To connect the emulation probe to a power source	22
Connection Sequence	23
To power on the system	23
To power off the system	23

Additional Information Sources	24
--------------------------------	----

2 Designing a Target System for an Emulation Probe 25

- Target System Requirements 26
- PowerPC JTAG interface connections and resistors 28

3 Installing the Optional Emulation Module 31

- To install the emulation module in an Agilent 16700-series logic analysis system or expansion frame 33
- To connect the E5901B emulation module to the E5900B emulation probe 35

4 Connecting the Emulation Probe to a LAN 37

- To choose a point-to-point or site LAN connection 38
- Connecting the Emulation Probe to a Site LAN 40
 - To obtain an IP address 41
 - To configure LAN parameters using a serial connection 42
 - To configure LAN parameters using DHCP 45
 - What is DHCP? 46
 - How does the emulation probe use DHCP? 46
 - How does DHCP interact with other methods of setting LAN parameters? 46
 - To configure LAN parameters using a logic analysis system without an emulation module 47
 - To configure LAN parameters using a logic analysis system with an emulation module 48

Setting up a Point-to-Point Connection	49
To set up a point-to-point connection with an emulation module	49
To set up a point-to-point connection without an emulation module	50
Verifying LAN Communications	51
To verify LAN communications using ping	51
To verify LAN communications using telnet	52

5 Installing Software on a 16700-Series Logic Analysis System 53

Installing and loading	54
What needs to be installed	55
To install the software from CD-ROM	56
To list software packages which are installed (16700)	57

6 Connecting the Emulation Probe to Your Target System 59

To connect the emulation probe to the target system	61
---	----

7 Configuring the Emulation Probe 63

What can be configured	64
Configuration items	65
To configure the processor type	65
To configure the JTAG clock speed (communication speed)	66

Contents

Configuring the Emulation Probe for Maximum Performance	67
To configure reset operation	69
To configure reset vector address	69
To configure the memory model	70
To configure address translation	71
To configure checkstop status	72
To configure the Break In SMB port	73
To configure the Trigger Out SMB port	74
To configure restriction to real-time runs	75
To set the memory read delay	76
To set the memory write delay	77
To configure the voltage reference	78
To configure the voltage threshold	78
Memory mapped registers (MPC8255 and MPC8260/64/65/66only)	79
To configure 32-bit mode (MPC8240, MPC8241, and MPC8245 only)	79
To enable or disable processor caches	80

8 Using the Emulation Probe 81

Using the Emulation Probe	82
Using the Emulation Probe with a Debugger	83
Using the emulation probe with a 16700-series logic analysis system via an emulation module	85
Using the emulation probe with a 16700-series logic analysis system via a LAN connection	86
Using the Emulation Probe Command Line Interface	88

Contents

Establishing a telnet connection to the emulation probe prior to using the command line interface 88

Using the command line interface from the logic analysis system 89

Exporting the Logic Analysis System's Display 90

To export the logic analysis system's display to a web browser 90

To export the logic analysis system's display to a UNIX workstation 90

To export the logic analysis system's display to a PC 91

9 Testing Target System Memory 93

Two ways to run the memory tests 94

Using the memory tests with an Agilent 16700 logic analysis system 95

Using the memory tests from a command line interface 96

Memory Test Patterns 97

Recommended Test Procedure 98

Basic Pattern test 99

Address Pattern test 102

Rotate Pattern test 104

Walking Ones test 106

Walking Zeros test 107

Oscilloscope Read test 108

Oscilloscope Write test 109

10 Updating Firmware 111

Updating Firmware When Operating With a Debugger 113

To display current firmware version information 113

To update firmware from the web 113

To update firmware from a floppy disk	113
Updating Firmware With a Logic Analysis System	114
To display current firmware version information	114
To update firmware using the Emulation Control Interface	115
To update firmware for an emulation probe using the Setup Assistant	116

11 Installing an Agilent E5902B Emulation Migration Kit 117

Will I need to change the target board adapter?	118
To install the emulation migration	119

12 Troubleshooting the Emulation Probe 123

General Troubleshooting	125
Step 1: Telnet to the emulation probe	125
If you cannot connect to the emulation probe	125
Step 2: Check the prompt	125
If a telnet connection to the emulation probe displays the prompt "->"	125
If a telnet connection to the emulation probe displays the prompt "?>"	126
Step 3: Try some simple commands to control the target	127
If the emulation probe has problems controlling the target	127
Step 4: Check the emulation module	128
If you have problems using the emulation probe as an emulation module in a 16700-series logic analysis system	128
Step 5: Check your debugger connection	129
If you have problems using the emulation probe with a debugger	129
If you need to obtain help	130
Status Lights	131

Contents

Emulation Probe Target Status Lights	131
Emulation Probe LAN Status Lights	132
Emulation Probe Power On Light	132
Using the Emulation Probe Command Line Interface	133
To list the emulation probe commands	133
To use the built-in commands	134
Examples of built-in commands	134
Emulation probe command line prompts	138
Configuration commands	139
Problems with the Target System	140
What to check first	140
To check the debug port connector signals	141
To interpret the initial prompt	142
If you see memory-related problems	146
If the processor spontaneously runs after break	147
If you see the "!ASYNC_STAT 173!" error message	148
If you see the "!"ERROR 145!" error message	148
Other error messages	149
Problems with the LAN Interface	150
If you cannot verify LAN communication	150
If you have LAN connection problems	151
If it takes a long time to connect to the network	151
If you have problems setting the LAN parameters using a logic analysis system	151
Problems with the Serial Interface	153
If you cannot verify RS-232 communication	153
If you have RS-232 connection problems with the MS Windows Terminal program	153
Problems with the Emulation Module	155
To test the emulation module	155

Contents

Problems with the Emulation Probe	156
To run the emulation probe performance verification tests	156
To run the performance verification tests using the logic analysis system	156
To run complete performance verification tests using a serial or telnet connection	157
If a performance verification test fails	158
If there are random problems	159
Returning Parts for Service	161
To return a part to Agilent Technologies	161
To obtain replacement parts	162
To clean the instrument	163

13 Specifications and Characteristics 165

Operating characteristics	166
Input/Output Electrical Characteristics	167
Trigger Out SMB Port	167
Break In SMB Port	167
Communication Ports	167
Power Supply	167
E5900B Emulation Probe Characteristics	168
Output Model	169
Environmental Characteristics	170
Emulation module environmental characteristics	170

Glossary 171

Index 177

Overview

Chapter 1: Overview

This chapter describes:

- Setup flowchart
- Equipment used with the emulation probe
- Equipment used with the emulation module
- Equipment used with the emulation migration
- Connection sequences for the emulation probe
- Additional information sources

Setup Flowchart

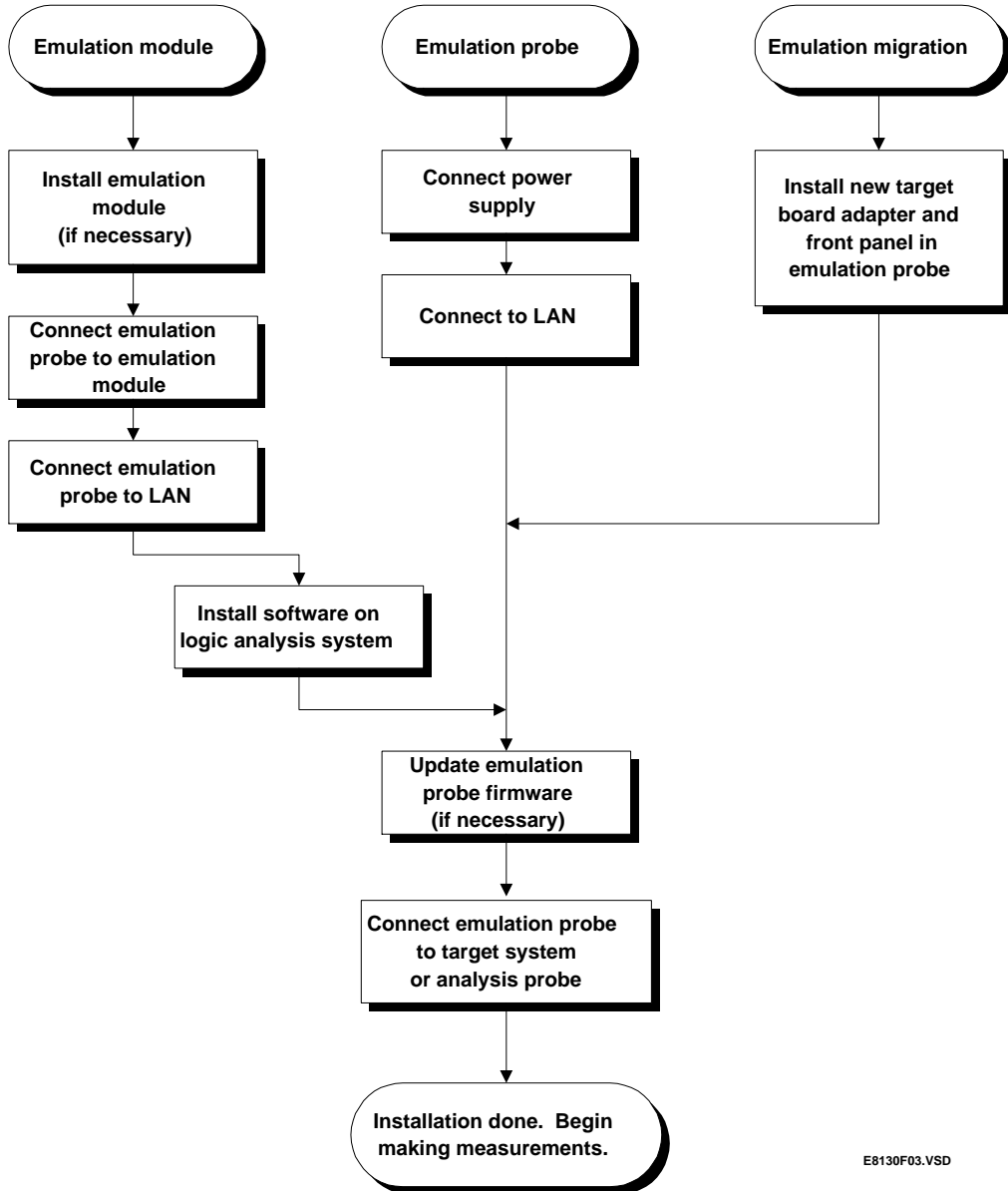

E8130F03.VSD

Agilent E5900B Emulation Probe

Equipment supplied

Part Number	Description
E3453B	Emulation probe
0950-3043	12V power supply for the emulation probe.
xxxx-xxxx	Power cord. Part number depends on country of use.
E8130-68703	Ferrite. Reduces electromagnetic interference on power cord.
E8130-68702	Cable kit consisting of a serial cable and RJ12-to-DB9 adapter, for setting the emulation probe's IP address from a PC.
E3494-61604	16-pin JTAG ribbon cable. Connects the emulation probe to the target debug port.
E3453-97008	This <i>User's Guide</i> .

Minimum equipment required

The following equipment is required to use the emulation probe:

- A method for connecting the emulation probe to the target system. The target system must have an appropriate JTAG (Joint Test Action Group) debug port connector. The target system must meet the criteria described in Chapter 2, "Designing a Target System for an Emulation Probe," beginning on page 25.
- A host computer, such as a PC or workstation. You can also connect the emulation probe to an Agilent 16700-series logic analysis system.
- A LAN (local area network) if you want to connect the emulation probe to a host computer.
- A user interface on the host computer, such as a high-level source debugger or the logic analysis system's Emulation Control Interface.

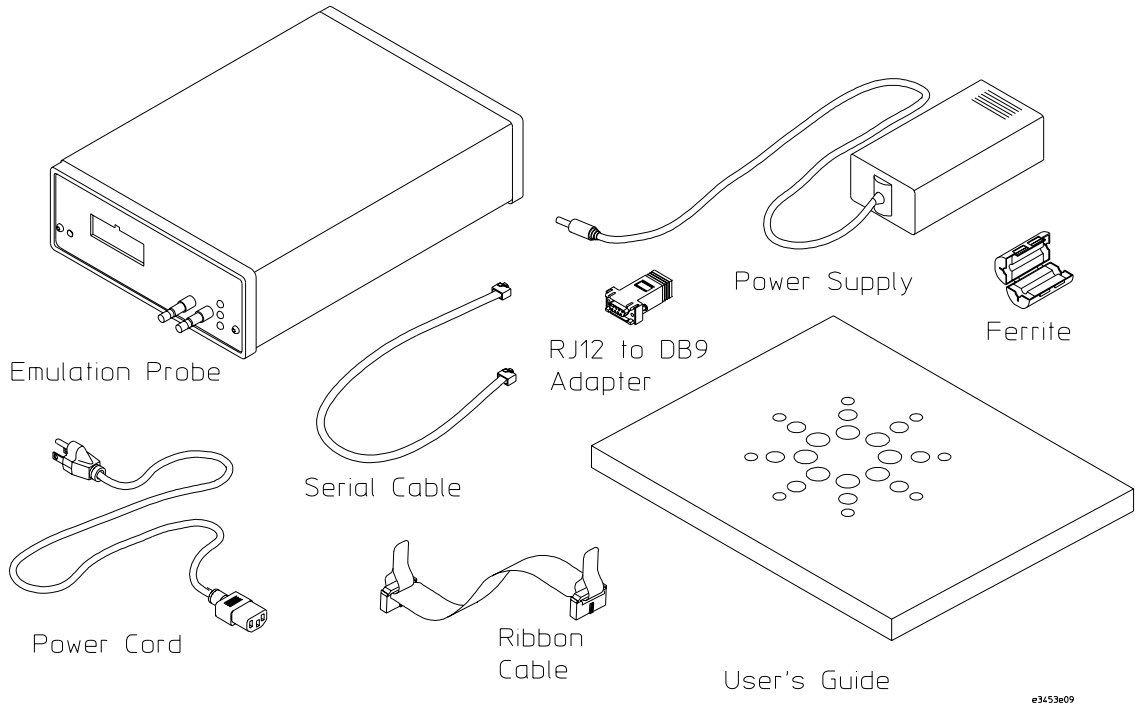

e3453e09

Agilent E5901B Emulation Module Kit

Equipment supplied

The Agilent E5901B emulation module facilitates communication between the Agilent 16700-series logic analysis system and the Agilent E5900B emulation probe. If you ordered an emulation module as part of your Agilent 16700-series logic analysis system, it is already installed in the frame.

The equipment supplied with your emulation module includes:

- All of the parts listed for the Agilent E5900B emulation probe on page 16 (except the serial cable and RJ12-to-DB9 adapter), and:

Part Number	Description
E5901B	Agilent E5901B emulation module.
5061-7342	LAN crossover cable (for point-to-point LAN connection only).
B3760A	Emulation probe firmware, and logic analyzer software on a CD-ROM.
E8130-61601	14-pin probe-to-emulation module interconnect cable. This is shipped attached to the emulation module. It connects the emulation module to the emulation probe.
E5901-68701	Module installation kit consisting of the emulation module-to-logic analyzer expansion cable and Torx T-10 and T-15 screwdrivers. NOTE: This kit is included only when the module is ordered without a logic analysis system. If a module is ordered with a logic analysis system, the module will be installed at the factory and the installation kit will not be included.

Minimum equipment required

The following equipment is required to use the emulation module:

- A method for connecting the emulation probe to the target system. The target system must have an appropriate JTAG debug port connector as described in Chapter 2, “Designing a Target System for an Emulation

Probe,” beginning on page 25.

- An Agilent 16700-series logic analysis system.
- A user interface, such as a high-level source debugger or the logic analysis system’s Emulation Control Interface.

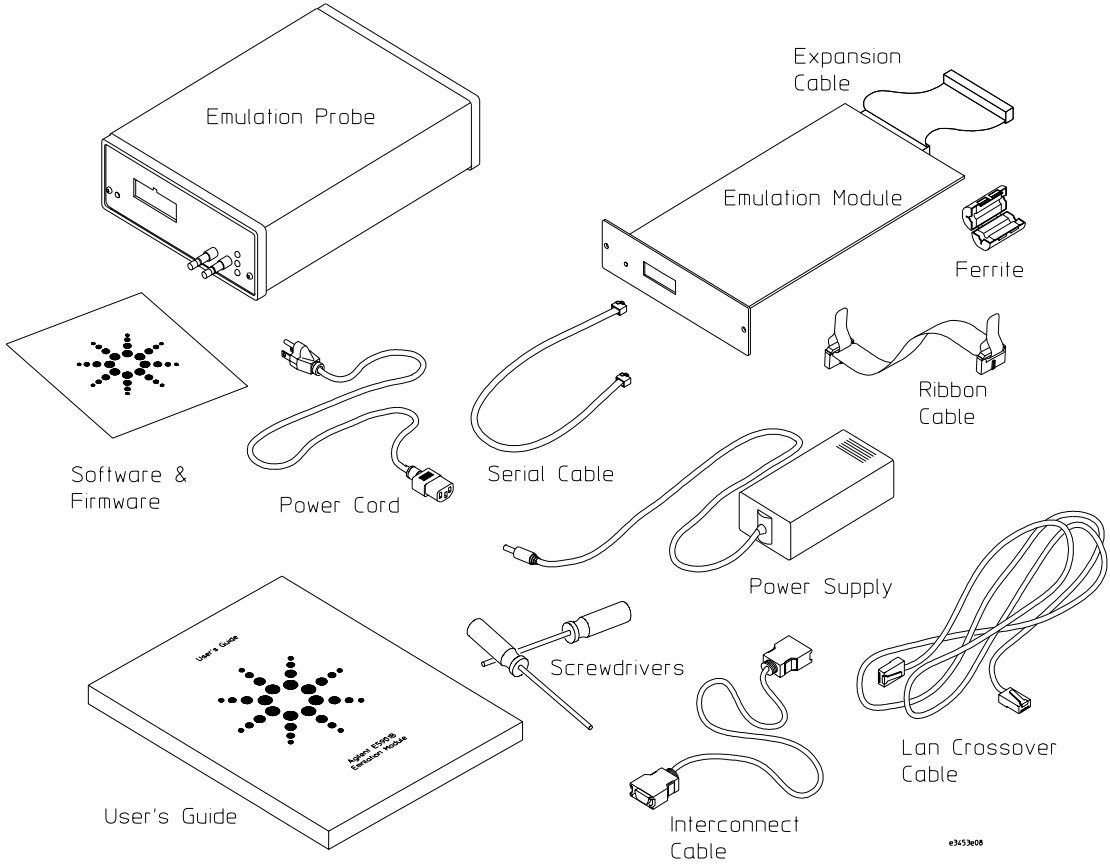

Agilent E5902B Emulation Migration Kit

Equipment supplied

The equipment supplied with your emulation migration includes:

Part Number	Description
E8130-66503	Target board adapter (formerly called cable board). This board customizes the emulation probe for a particular target type. It is called "6XX cable board" on the contents list.
E8130-00201	Front panel for the emulation probe.
E8130-68701	Tool kit: 1/4 inch wrench, Torx T-10 screwdriver, and a #1 Phillips screwdriver.
E3494-61604	16-pin JTAG ribbon cable. This connects the emulation probe to the target debug port.
B3760A	Emulation probe firmware, and logic analyzer software on a CD-ROM.
E3453-xxxxx	Firmware for the emulation probe on a 3.5-inch disk, for use if you do not have an Agilent logic analysis system.
E3453-97008	This <i>User's Guide</i> .

Minimum equipment required

The following equipment is required to use the emulation migration:

- An Agilent E5900B emulation probe.
- A method for connecting the emulation probe to the target system. The target system must have an appropriate JTAG debug port connector. The target system must meet the criteria described in Chapter 2, "Designing a Target System for an Emulation Probe," beginning on page 25.
- A host computer such as a PC, a workstation, or an Agilent 16700-series logic analysis system.
- A user interface, such as a high-level source debugger or the logic analysis system's Emulation Control Interface.

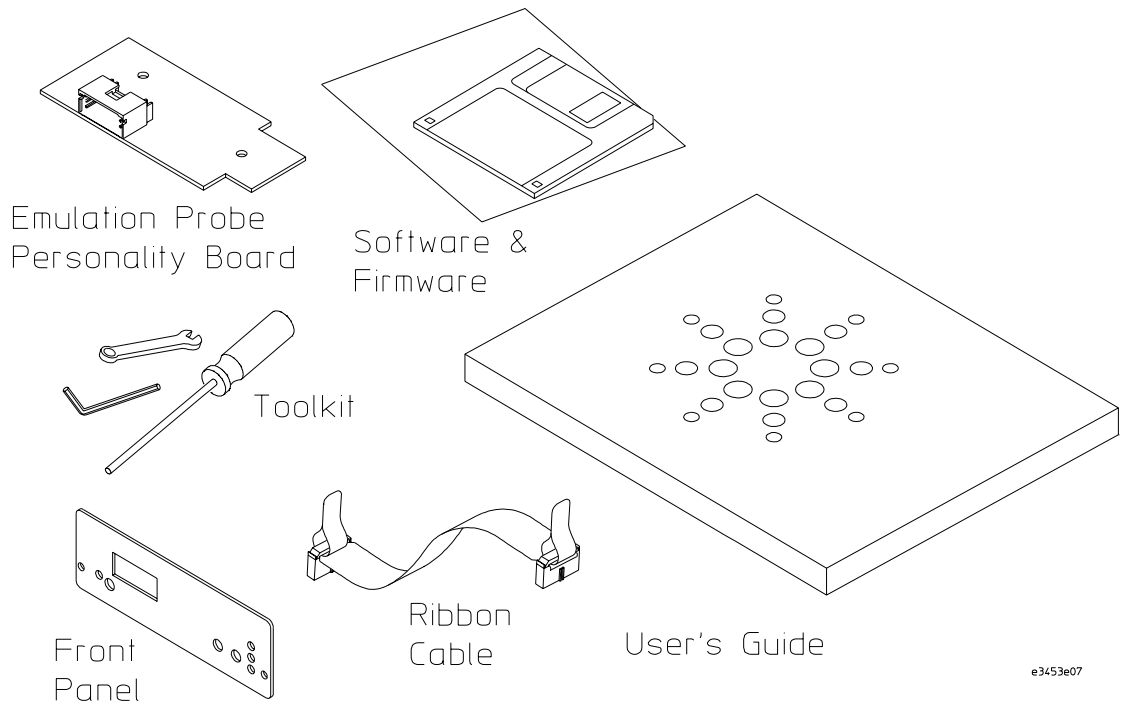

e3453e07

To connect the emulation probe to a power source

The emulation probe is shipped from the factory with a power supply and cord appropriate for your country. (The power supply you received may look different from the one illustrated below.) If the cord you received is not appropriate for your electrical power outlet type, contact your Agilent Technologies sales and service office.

WARNING:



Use only the supplied Agilent power supply and cord. Failure to use the proper power supply could result in electric shock.

CAUTION:

Use only the supplied Agilent power supply and cord. Failure to use the proper power supply could result in equipment damage.

- 1 Install the ferrite on the 12V power cord, near the end which plugs into the emulation probe.
- 2 Connect the power cord to the power supply and to a socket outlet.

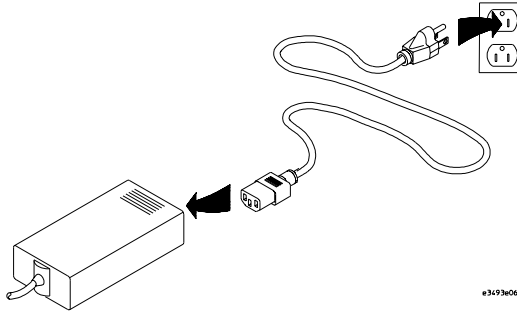

- 3 Connect the 12V power cord to the back of the emulation probe.

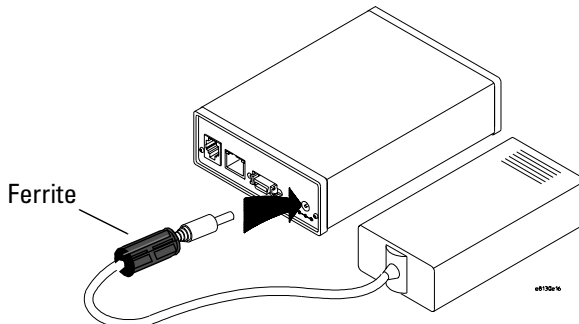

- 4 Turn on the emulation probe power switch.

Connection Sequence

Disconnect power from the target system, emulation probe, and logic analyzer before you make or break connections.

- 1 Connect the emulation probe to a LAN (page 37).
- 2 Connect the emulation probe to your target system (page 59).
- 3 Configure the emulation probe (page 63).

To power on the system

With all components connected, power on your system as follows:

- 1 Logic analyzer, if you are using one.
- 2 Emulation probe.
- 3 Your target system.

To power off the system

Power off your system as follows:

- 1 Your target system.
- 2 Emulation probe.
- 3 Logic analyzer, if you are using one.

Additional Information Sources

Additional or updated information can be found in the following places:

Newer editions of this manual may be available. Contact your local Agilent Technologies representative.

If you ordered an inverse assembler, the manual supplied with your inverse assembler will provide additional information.

If you have an analysis probe, the instructions for connecting the probe to your target microprocessor are in the analysis probe documentation. The documentation supplied with the analysis probe provides information about using the analysis probe and emulation probe together.

Application notes may be available from your local Agilent representative or on the World Wide Web at:

<http://www.agilent.com/find/emulator>

If you have an Agilent 16700-series logic analysis system, the **online help** for the Emulation Control Interface has additional information on using the emulation probe.

The **measurement examples** include valuable tips for making emulation and analysis measurements. You can find the measurement examples under the system help in your Agilent 16700-series logic analysis system.

The latest firmware versions and additional utilities can be found on the World Wide Web at **<http://www.cos.agilent.com/probe>**.

Designing a Target System for an Emulation Probe

This chapter will help you design a target system that will work with the emulation probe.

Target System Requirements

Unsupported modes

Target systems that use any of the following modes of operation are not currently supported:

- Address parity is not generated on external address bus operations. Accesses to devices that check parity will fail.

TDO, TDI, TCK, TMS and $\overline{\text{TRST}}$ signals

TDO, TDI, TCK, TMS and $\overline{\text{TRST}}$ signal traces between the JTAG debug port connector and the processor must be less than 3 inches long. If these signals are connected to other nodes, the other nodes must be daisy chained between the JTAG connector at one end and the PowerPC microprocessor at the other end. These signals are sensitive to crosstalk and must not be routed along active signals such as clock lines on the target board.

The TDI, TCK, TMS and $\overline{\text{TRST}}$ signals must not be actively driven by the target system when the JTAG debug port is being used.

Reset Vector Address

After a system reset, the processor can be directed to boot from one of two locations. This allows the developer flexibility in booting from either ROM or RAM.

You can choose the start location after a reset by using the reset operation configuration command (see page 69) and the reset vector configuration command (see page 69). The location can be fff00100 (the traditional location of ROM) or 00000100 (a RAM reset location). The use of a RAM location allows you to rapidly re-compile, load, and then test your boot-up sequence without having to re-flash ROM.

Reset signals

The $\overline{\text{HRESET}}$, $\overline{\text{SRESET}}$ and $\overline{\text{TRST}}$ signals from the JTAG connector must be wire Ored with the $\overline{\text{HRESET}}$, $\overline{\text{SRESET}}$ and $\overline{\text{TRST}}$ signals that connect to the processor on the target system.

MPC82XX Target Processor PC Board

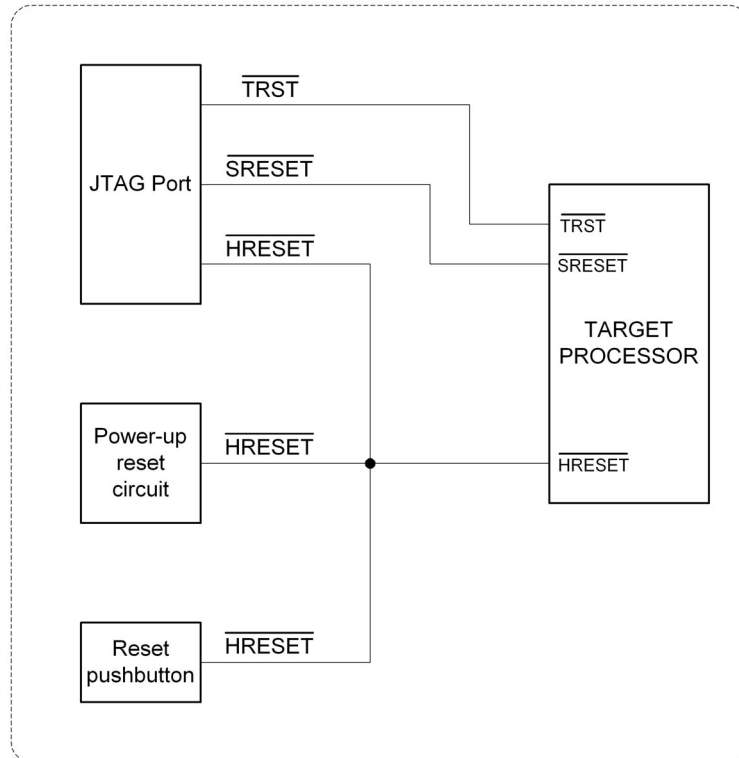

The emulation probe adds capacitance to all target system signals routed to the JTAG debug port connector. This added capacitance may increase the rise time and/or fall time of the reset signals beyond target processor specifications. Decreasing the value of the pull-up resistor on a line will decrease its rise time.

Consult the following sources for more information:

- See the tables on page 29 for recommended pull-up resistor values.
- See the tables on page 168 for emulation probe input and output

- capacitance values.
- See the processor manufacturer's data sheet for rise/fall time specifications.

PowerPC JTAG interface connections and resistors

The target system must have a 16-pin male 2x8 header connector with dimensions as shown below.

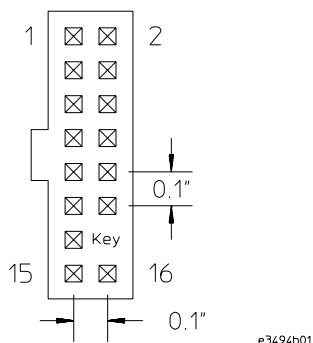

JTAG Header Connector (top view)

Position 14 of the connector on the target system must not contain a pin. The cable supplied with the emulation probe can only be installed if pin 14 has been removed from the target system header.

Place the connector as close as possible to the processor to ensure signal integrity.

MPC82XX Connections

Header Pin Number	Signal Name	I/O	Board Resistor
1	TDO	Out	
2	Not connected		
3	TDI	In	1 k Ω pulldown
4	$\overline{\text{TRST}}$	In	10 k Ω pullup ¹
5	Not connected		
6	+POWER ² (V_{ref})		1 k Ω series ³
7	TCK	In	10 k Ω pullup
8	Not connected		
9	TMS	In	10 k Ω pullup
10	Not connected		
11	$\overline{\text{SRESET}}$	In	10 k Ω pullup
12	Not connected		
13	$\overline{\text{HRESET}}$	In	10 k Ω pullup
14	KEY		
15	CSTP_OUT	Out	1 k Ω pullup
16	GND		
	$\overline{\text{QACK}}$ ⁴	In	1 k Ω pulldown
	L2_TEST_CLK	In	10 k Ω pullup
	L1_TEST_CLK	In	10 k Ω pullup
	LSSD_MODE	In	10 k Ω pullup
	ARRAY_WR	In	10 k Ω pullup

¹ To ensure TAP stability some processors may require $\overline{\text{TRST}}$ to be held low when the emulation probe is not connected to the target. In this case a 2 k Ω pulldown resistor can be used instead of a 10 k Ω pullup resistor.

² The +POWER signal (also called V_{ref}) is sourced from the target system and is used as a reference signal. It should be the power signal being supplied to the processor (in the range of 2.0 V to 5.0 V). It does not supply power to the emulation probe.

³ This 1 k Ω series resistor provides short circuit current limiting protection only. If the resistor is present, it should be 1 k Ω or less.

⁴ If the target system does not use $\overline{\text{QACK}}$, the board must have a 1 k Ω pulldown resistor connected to this pin. This signal allows the emulation probe to force the processor into soft stop mode. If the target system does use this signal, it should provide logic so that $\overline{\text{QACK}}$ goes low in response to a $\overline{\text{QREQ}}$.

Installing the Optional Emulation Module

Chapter 3: Installing the Optional Emulation Module

This chapter shows you how to install the optional emulation module in your Agilent Technologies 16700-series logic analysis system and how to connect the emulation module to an emulation probe.

If you are not using an Agilent logic analysis system with your emulation probe, or if your emulation module is already installed in your logic analysis system frame, you may skip this chapter.

CAUTION:

Electrostatic discharge (ESD) can damage electronic components. Observe standard ESD precautions. Use grounded wrist straps and mats when you handle modules.

You will need to set up a LAN connection for the E5900B emulation probe, even if you are using an E5901B emulation module.

To install the emulation module in an Agilent 16700-series logic analysis system or expansion frame

You will need T-10 and T-15 Torx screw drivers (supplied with the emulation module)

- 1 Turn off the logic analysis system and REMOVE THE POWER CORD.
Remove any other cables (including mouse or video monitor cables).
- 2 Turn the logic analysis system frame upside-down.
- 3 Remove the bottom cover.

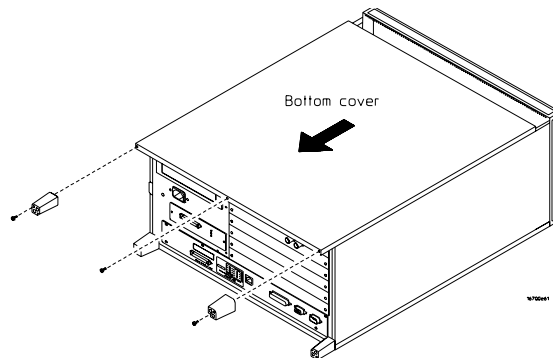

- 4 Remove the slot cover.

NOTE:

The 16700B-series logic analysis system (which is shown here) has one available slot. If you have a 16700A-series logic analysis system, you may use either of the two slots.

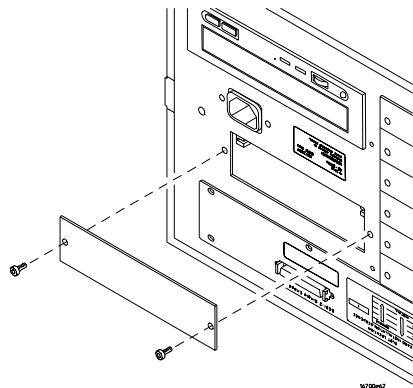

- 5 Install the emulation module.

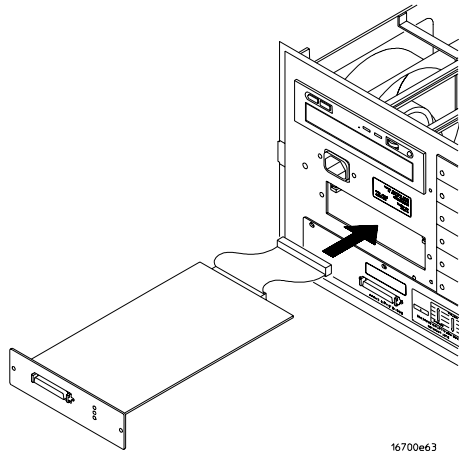

- 6 Connect the cable and re-install the screws.

NOTE:

The 16700B-series logic analysis system (which is shown here) has one available connector. If you have a 16700A-series logic analysis system, you may connect the cable to either of the two connectors.

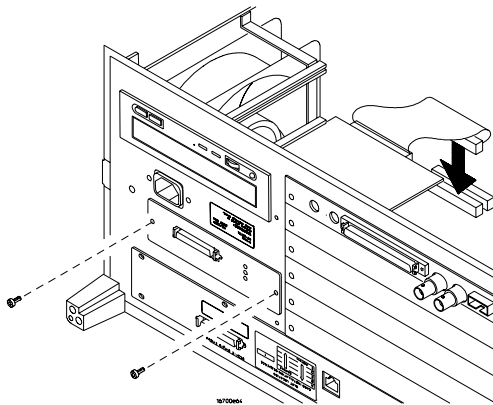

- 7 Reinstall the bottom cover, then turn the frame right-side-up.
- 8 Plug in the power cord, reconnect the other cables, and turn on the logic analysis system.

The new emulation module will be shown as an "E5901B Emulation Module" in the system window.

To connect the E5901B emulation module to the E5900B emulation probe

- 1 Connect one end of the module/probe interconnect cable to the E5901B emulation module in the logic analysis system mainframe.
- 2 Connect other end of the module/probe interconnect cable to the "Emulation Module" connector on the E5900B emulation probe.

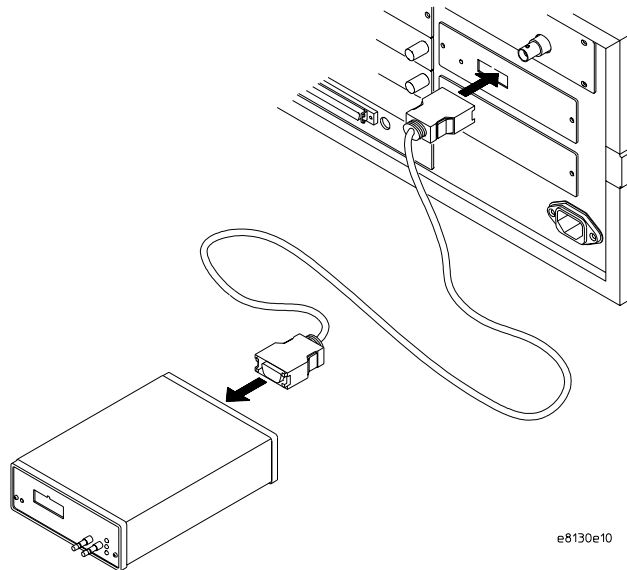

- 3 Power on the emulation probe.

The LED next to the switch is lit when the switch is turned on and the probe is being supplied with power.

Power is supplied by the 16700-series logic analysis system through the module/probe interconnect cable. The external power supply is not necessary for normal operation.

See Also

Chapter 4, "Connecting the Emulation Probe to a LAN," beginning on page 37. (You need to connect the emulation probe to the LAN, even when you are using an emulation module.)

Chapter 6, "Connecting the Emulation Probe to Your Target System," beginning on page 59.

Connecting the Emulation Probe
to a LAN

To choose a point-to-point or site LAN connection

You need to set up a LAN connection for the E5900B emulation probe, even if you are using an E5901B emulation module.

The emulation probe has an IEEE 802.3 Type 10/100Base-TX LAN connector.

The emulation probe is compatible with both 10 Mbps (10BASE-T) and 100 Mbps (100BASE-TX) twisted-pair ethernet LANs. The probe automatically negotiates the data rate for the LAN it is connected to.

Before the Emulation Control Interface can connect to the emulation probe, the probe's LAN parameters (that is, its IP address, gateway address, and subnet mask) must be set up. The IP address and other network parameters are stored in nonvolatile memory within the emulation probe.

See Also

For information on connecting a debugger to the emulation probe, see Chapter 8, “Using the Emulation Probe,” beginning on page 81.

To choose a point-to-point or site LAN connection

You can connect the emulation probe to your site LAN, or you can create an isolated network between a 16700-series logic analysis system and the emulation probe using a point-to-point connection.

A point-to-point connection is especially useful when you have a 16700-series logic analysis system, and:

- You do not have a site LAN, or
- The measurement setup will be on a cart, or
- You do not want to connect the measurement setup to a LAN because of security reasons.

Advantages of a point-to-point connection:

- If you have an E5901B emulation module, all LAN parameters will be set automatically.
- No need for a system administrator to assign IP addresses. (You can use any IP address for the emulation probe, and it will not conflict with other devices on the LAN.)
- The logic analysis system cannot be accessed across the network (required in some high-security environments).
- Can be used when a site LAN is not available.

Disadvantages of a point-to-point connection:

- Neither logic analysis system nor the emulation probe are connected to a site LAN.
- A special "crossover" LAN cable must be used.
If you have an emulation module, use the LAN crossover cable supplied with the emulation module (Agilent part number 5061-7342). If you do not have an emulation module, use a Category 3 (for 10BASE-T) or Category 5 (for 100BASE-TX) crossover cable.
- The emulation probe must be near the logic analysis system. The length of the crossover cable supplied with the emulation module is 1.5m (5 feet).
- Remote file systems cannot be mounted for access to source code files, symbol files, or executable files.
- The emulation probe cannot be controlled by a debugger on a host computer.

Connection Method	Go to Page
Site LAN connection	page 40
Point-to-point	page 49

Connecting the Emulation Probe to a Site LAN

Connecting the Emulation Probe to a Site LAN

- 1 Connect the LAN cable to the connector on the emulation probe.

Be sure to use the appropriate Category 3 or Category 5 cable for your LAN. Do not use the LAN cable supplied with the emulation probe—it is a crossover cable used for point-to-point connections only.

- 2 Find out the IP address and other LAN parameters to use for the emulation probe. See “To obtain an IP address” on page 41.
- 3 Decide how you want to configure the LAN parameters:

If you have this equipment...	Use this procedure
Emulation probe only	“To configure LAN parameters using a serial connection” on page 42, or “To configure LAN parameters using DHCP” on page 45
Emulation probe and a logic analysis system without an E5901B emulation module	“To configure LAN parameters using a logic analysis system without an emulation module” on page 47
Emulation probe and a logic analysis system with an E5901B emulation module	“To configure LAN parameters using a logic analysis system with an emulation module” on page 48

- 4 Verify that your emulation probe is now active and on the network. See “To verify LAN communications” on page 51.

To obtain an IP address

- 1 Obtain the following information from your local network administrator or system administrator:

- An IP address for the emulation probe.

You can also use a "LAN name" for the emulation probe, but you must configure it using the integer dot notation (such as 127.0.0.1).

- The gateway address.

The gateway address is an IP address and is entered in integer dot notation. The default gateway address is 0.0.0.0, which allows connections only on the local network or subnet. If connections are to be made to workstations on other networks or subnets, this address must be set to the address of the gateway machine.

- The subnet mask.

A subnet mask blocks out part of an IP address so that the networking software can determine whether the destination host is on a local or remote network. It is usually represented as decimal numbers separated by periods; for example, 255.255.248.0.

- 2 Find out whether port numbers 6470 and 6471 are already in use on your network and if that use constitutes a conflict.

The host computer interfaces communicate with the emulation probe through two TCP service ports. The default base port number is 6470. The second port has the next higher number (default 6471).

In almost all cases, the default numbers (6470, 6471) can be used without change. If necessary the base port number can be changed if the port numbers conflict with some other product on your network.

To change the port numbers, see page 44. If you have already set the IP address, you can use a telnet connection instead of a serial connection to connect to the emulation probe.

To configure LAN parameters using a serial connection

The E5900B emulation probe has a 9600 baud RS-232 serial interface with an RJ12 connector.

The emulation probe is shipped with a serial cable (with RJ-12 connectors on both ends, with 6-wire straight-through connections) and an adapter (female RJ-12 to female 9-pin D subminiature). The adapter plugs into the 9-pin serial port found on most PCs.

Serial connections on a workstation

If you are using a UNIX[®] workstation as the host computer, you need to use a serial device file. If a serial device file does not already exist on your host, you need to create one. Once it exists, you need to ensure that it has the appropriate permissions so that you can access it. See the system documentation for your workstation for help with setting up a serial device.

Serial connections on a PC

Serial connections are supported on PCs. You must use hardware handshaking if you will use the serial connection for anything other than setting LAN parameters.

If you are using a PC as the host computer, you do not need to set up any special files.

- 1 Connect the serial cable from the host computer to the emulation probe.

Use the DB9-to-RJ12 adapter and the serial cable supplied with the emulation probe.

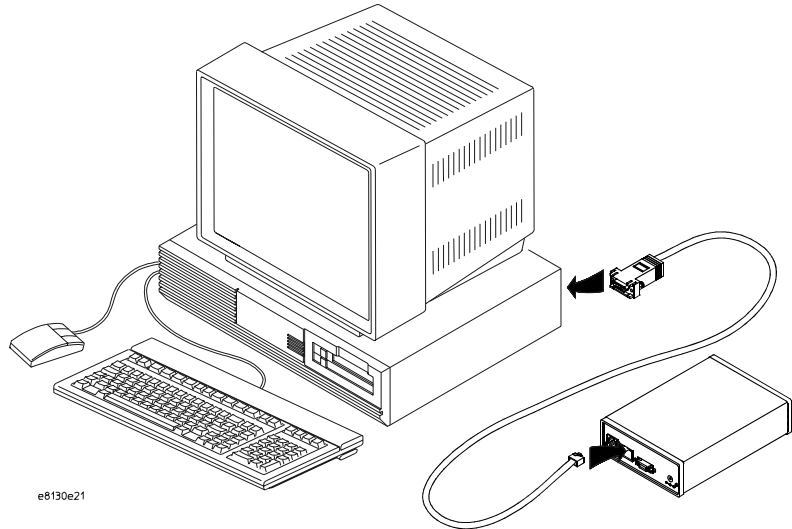

- 2 Start a terminal emulator program on the host computer.

If you are using a PC, the HyperTerminal application in Microsoft® Windows® will work fine.

If you are using a UNIX workstation, you can use a terminal emulator such as cu or kermi.

- 3 Configure the terminal emulator program for:

- Communication rate: 9600 baud
- Bits: 8
- Parity: none
- Stop bits: 1
- Flow control: none

- 4 Turn on power to the emulation probe.

When the emulation probe powers up, it sends a version message to the serial port, followed by a prompt.

- 5 Press the Return or Enter key a few times.

Connecting the Emulation Probe to a Site LAN

You should see a prompt such as "p>" or "R>".

For information about the commands you can use, enter ? or help at the prompt.

- 6 Display the current LAN configuration values by entering the **lan** command:

```
R> lan
lan is enabled
  Link Status is UP
  100BaseTX
  lan -i 15.5.24.116
  lan -g 15.5.23.1
  lan -s 255.255.248.0
  lan -p 6470
  Ethernet Address : 08000909BAC1
R>
```

The Ethernet address, also known as the link level address, is preassigned at the factory, and is printed on a label on the emulation probe.

- 7 Enter the following command:

```
lan -i <internet> [-g <gateway>] [-p <port>] [-s
<subnet>]
```

The lan command parameters are:

- i **<internet>** The IP address which you obtained from your network administrator.
- g **<gateway>** The gateway address. Setting the gateway address allows access outside your local network or subnet.
- s **<subnet>** This changes the subnet mask.
- p **<port>** This changes the base TCP service port number, normally 6470.

Do not change the default port numbers (6470, 6471) unless they conflict with some other product on your network. The numbers must be greater than 1024. If you change the base port, enter the new value in the configuration of your debugger (and, for UNIX workstations, in the /etc/services file).

- 8 Cycle power on the emulation probe.

The IP address and any other LAN parameters you change are stored in nonvolatile memory and will take effect when the emulation probe is powered

off and back on again.

Example

To assign an IP address of 192.6.94.2 to the emulation probe, enter the following command:

```
R>lan -i 192.6.94.2
```

Cycle power on the emulation probe so that the new address will take effect.

- 9 Verify your emulation probe is now active and on the network. See “Verifying LAN Communications” on page 51.

Once you have set a valid IP address, you can use the telnet utility to connect to the emulation probe, and use the lan command to change LAN parameters.

To configure LAN parameters using DHCP

If there is a DHCP server on your network which responds to BOOTP requests and supports “static allocation” of IP addresses, it can be used to set the emulation probe’s LAN parameters.

- 1 Ask your system administrator to set up an IP address for the emulation probe on the DHCP server.

You will need to supply the link-level address of the emulation probe.

The link-level address (LLA) is printed on a label above the LAN connector on the emulation probe. This address is configured in each emulation probe shipped from the factory and cannot be changed.

- 2 Connect the LAN cable to the connector on the emulation probe.
- 3 Cycle power on the emulation probe by powering it off then on again.
- 4 Wait at least 20 seconds for the emulation probe to recognize the LAN.
- 5 Verify that your emulation probe is now active and on the network. See "To verify LAN communications" on page 51.

What is DHCP?

DHCP (Dynamic Host Configuration Protocol) allows clients to obtain LAN parameters automatically from a server.

How does the emulation probe use DHCP?

The emulation probe uses “static allocation” (sometimes called “manual allocation”) to obtain a permanent IP address. Every time the emulation probe is turned on, it sends out a BOOTP request packet. If the DHCP server on the network responds to BOOTP requests and has been configured to reply to the emulation probe’s link-level address, it will respond with the IP address and other LAN parameters.

The emulation probe does not support “automatic allocation”, which permanently allocates IP addresses from a pool of addresses.

Nor does the emulation probe support “dynamic allocation” of IP addresses—it does not track lease duration and request a new IP address when the lease is about to expire.

How does DHCP interact with other methods of setting LAN parameters?

Every time the emulation probe is turned ON, it sends out a BOOTP request packet (even if the LAN parameters have already been configured). As long as the DHCP server is configured to reply to BOOTP requests from the emulation probe’s link-level address, it will respond with the IP address and other LAN parameters.

To configure LAN parameters using a logic analysis system without an emulation module

- 1 Connect the LAN cable to the connector on the emulation probe.
- 2 In the logic analysis system interface, open the Workspace window by selecting the Workspace icon.



- 3 Scroll down the left side of the toolbox in the workspace window and find the emulation probe tool. Drag the emulation probe icon from the toolbox to the workspace.



- 4 From the emulation probe icon, select **Init Probe LAN Addresses....**
- 5 Enter the link-level address of the probe you wish to set up.
- 6 Enter the internet address, gateway IP and subnet mask in the appropriate fields.
- 7 Select **OK**.

If "ERROR - no response from emulation probe" is displayed, check that the emulation probe is properly connected to the LAN. Then try selecting **OK** again.

If no error message is displayed, the internet address and other network parameters will be stored in nonvolatile memory and will take effect when power is cycled.

- 8 Cycle power on the emulation probe by powering it off then on again.

Connecting the Emulation Probe to a Site LAN

To configure LAN parameters using a logic analysis system with an emulation module

- 1 Connect the emulation module to the emulation probe. (See page 35.)
- 2 Connect the LAN cable to the connector on the emulation probe.
- 3 Cycle power on the emulation probe by powering it off then on again.
- 4 Wait at least 20 seconds for the emulation probe to recognize the LAN.
- 5 From the E5901B emulation module icon, select **Modify Interconnected Probe LAN Addresses...**

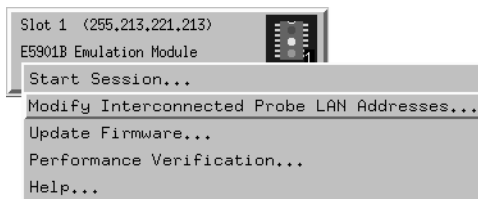

- 6 Select **Read Probe Addresses** to read the current settings.
- 7 Enter the internet address, gateway IP and subnet mask in the appropriate fields.
- 8 Select **OK**.
- 9 Cycle power on the emulation probe. The new addresses will take effect after you cycle power.

Setting up a Point-to-Point Connection

A point-to-point connection creates an isolated network with only two nodes—the logic analysis system and the emulation probe.

There are two ways to set up the connection:

If you have this equipment...	Use this procedure
Emulation probe and a logic analysis system <i>with</i> an E5901B emulation module	“To set up a point-to-point connection with an emulation module” on page 49
Emulation probe and a logic analysis system <i>without</i> an E5901B emulation module	“To set up a point-to-point connection without an emulation module” on page 50

To set up a point-to-point connection with an emulation module

- 1 Connect the emulation module to the emulation probe (page 35).
- 2 Connect the crossover LAN cable between the logic analysis system and the emulation probe.
- 3 In the logic analysis system main window, open the System Administration dialog and check that networking is enabled.
- 4 Select the emulation module icon then select **Start Session....**

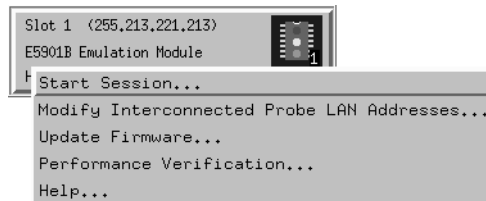

This will automatically configure the LAN connection and start the Emulation Control Interface. There is no need to set the IP address of the emulation probe.

To set up a point-to-point connection without an emulation module

- 1 Connect the crossover LAN cable between the logic analysis system and the emulation probe.
- 2 Turn on power to the emulation probe.
- 3 In the logic analysis system main window, select the System Administration icon.
- 4 Select **Network Setup...**
- 5 Select **Standard** to turn on networking.
- 6 Select **Default Network**.

Leave the network parameters with the default values. The IP address should be 192.0.2.231.

- 7 In the Network Setup dialog, select **OK**.
- 8 In the main system window, select the Workspace icon.
- 9 Drag the emulation probe icon onto the workspace.



- 10 From the emulation probe icon, select **Init Probe LAN Addresses...**
- 11 Enter the link-level address of the emulation probe.

The link-level address (LLA) is printed on a label above the LAN connector on the emulation probe.

- 12 Enter the following IP address: 192.0.2.233
- 13 Select **OK** then follow the instructions.

Note about the Setup Assistant: If networking is *disabled* for the 16700-series logic analysis system, the Setup Assistant will guide you through the process of setting up a point-to-point connection. If networking is *enabled*, the Setup Assistant assumes you want to connect the emulation probe to a site LAN.

Verifying LAN Communications

Verify your emulation probe is now active and on the network by issuing a **ping** or **telnet** command to the IP address.

To verify LAN communications using ping

These instructions assume you are using a PC running Microsoft Windows 95 or Windows 98. The procedure for other operating systems is slightly different.

- 1 Open an MS-DOS® window or select **Start→Run...**
- 2 Enter the **ping** command followed by the IP address of the emulation probe.

Example

```
C:\WINDOWS>ping 15.6.253.138
```

```
Pinging 15.6.253.138 with 32 bytes of data:
```

```
Reply from 15.6.253.138: bytes=32 time=1ms TTL=254  
Reply from 15.6.253.138: bytes=32 time=1ms TTL=254  
Reply from 15.6.253.138: bytes=32 time=1ms TTL=254  
Reply from 15.6.253.138: bytes=32 time<10ms TTL=254
```

If You Have Problems If the response is something like "100% packet loss" or "Destination host unreachable", see "Problems with the LAN Interface" on page 150.

To verify LAN communications using telnet

- 1 Verify your emulation probe is now active and on the network by issuing a telnet to the IP address.

This connection will give you access to the emulation probe's built-in terminal interface.

- 2 To view the LAN parameters, enter the lan command at the terminal interface prompt.
- 3 To exit from this telnet session, type Ctrl+D at the prompt.

The best way to change the emulation probe's IP address, once it has already been set, is to telnet to the emulation probe and use the terminal interface lan command to make the change. Remember, after making your changes, you must cycle power before the changes take effect. Doing this will break the connection and end the telnet session.

To use telnet on a 16700-series logic analysis system, select the System Administration icon, select the **Networking** tab, then select **telnet...**

If You Have Problems See "Problems with the LAN Interface" on page 150.

Example

```
$ telnet 192.35.12.6
R>lan
lan is enabled
lan -i 192.35.12.6
lan -g 0.0.0.0
lan -s 255.255.248.0
lan -p 6470
Ethernet Address : 08000F090B30
```

Installing Software on a 16700-Series
Logic Analysis System

This chapter explains how to install the software you will need for your analysis probe.

Installing and loading

Installing the software will copy the files to the hard disk of your logic analysis system. Later, you will need to **load** some of the files into the appropriate hardware module.

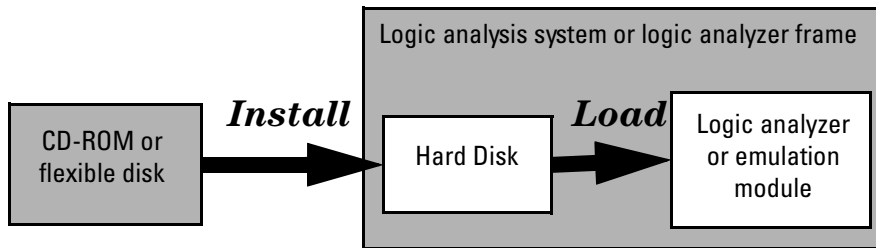

What needs to be installed

16700-series logic analysis systems

If you ordered this emulation probe *on the same order* with your logic analysis system, the software was installed at the factory.

The following files are installed when you install a processor support package from the CD-ROM:

- Logic analysis system configuration files
- Inverse assembler (automatically loaded with the configuration files)
- Personality files for the Setup Assistant
- Emulation module firmware
- Emulation Control Interface

The B4620B Source Correlation Tool Set is installed with the logic analysis system's operating system.

To install the software from CD-ROM

Installing a processor support package from a CD-ROM will take just a few minutes. If the processor support package requires an update to the Agilent Technologies 16700 operating system, installation may take approximately 15 minutes.

NOTE:

The 16700B-series logic analysis systems have internal CD-ROM drives. The 16700A-series logic analysis systems have external CD-ROM drives.

If your system uses an external CD-ROM drive and it is not connected, see the connection instructions printed on the CD-ROM package.

- 1 If your system uses an external CD-ROM drive, turn on the CD-ROM drive first and then turn on the logic analysis system. Otherwise, simply turn on the logic analysis system.

If the CD-ROM and analysis system are already turned on, be sure to save any acquired data. The installation process may reboot the logic analysis system.

- 2 Insert the CD-ROM in the drive.

- 3 Select the **System Administration** icon. 

- 4 Select the **Software Install** tab.

- 5 Select **Install...**

Change the media type to "CD-ROM" if necessary.

- 6 Select **Apply**.

- 7 From the list of types of packages, double-click "PROC-SUPPORT."

A list of the processor support packages on the CD-ROM will be displayed.

NOTE:

For touch screen systems, double select the "PROC-SUPPORT" line by quickly touching it twice.

- 8 Select the MPC82XX package.

If you are unsure whether this is the correct package, select **Details** for information about the contents of the package.

9 Select **Install**.

The Continue dialog box will appear.

10 Select **Continue**.

The Software Install dialog will display "Progress: completed successfully" when the installation is complete.

11 If required, the system will automatically reboot. Otherwise, close the software installation windows.

The configuration files are stored in a subdirectory of `/logic/configs/hp`. The inverse assemblers are stored in `/logic/ia`.

See Also

See the instructions printed on the CD-ROM package for a summary of the installation instructions.

See the online help for more information on installing, licensing, and removing software.

To list software packages which are installed (16700)

In the System Administration Tools window, under the **Software Install** tab, select **List...**

Connecting the Emulation Probe to Your Target System

Chapter 6: Connecting the Emulation Probe to Your Target System

This chapter shows you how to connect the emulation probe to the target system and how to configure the emulation probe and target.

Here is a summary of the steps for connecting and configuring the emulation probe:

- 1** Make sure the target system is designed to work properly with the emulation probe. (See page 25.)
- 2** Install the emulation module in your logic analysis system, if necessary. (See page 31.)
- 3** Connect the emulation probe to a LAN. (See page 37.)
- 4** Connect the emulation probe to your target system using the ribbon cable. (See page 61.)
- 5** Update the firmware of the emulation probe, if necessary. (See page 111.)
- 6** Configure the emulation probe. (See page 63.)
- 7** Connect a debugger to the emulation probe, if applicable. (See page 83.)

To connect the emulation probe to the target system

The emulation probe can be connected to a target system through a 16-pin JTAG port connector (a 16-pin male 2x8 header connector on the target system).

The emulation probe should be connected to the target system using the ribbon cable provided.

- 1** Turn off power to the target system.
- 2** Turn off power to the emulation probe.
- 3** Plug the un-keyed end (pin 14 is open) of the ribbon cable into the emulation probe.

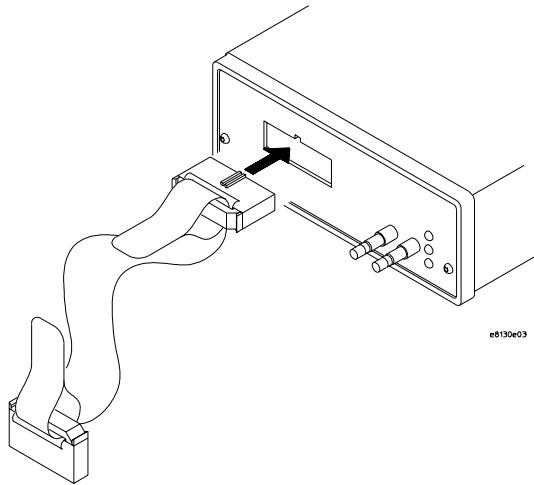

- 4 Plug the keyed end of the cable (pin 14 is blocked) into the JTAG debug port on the target system.

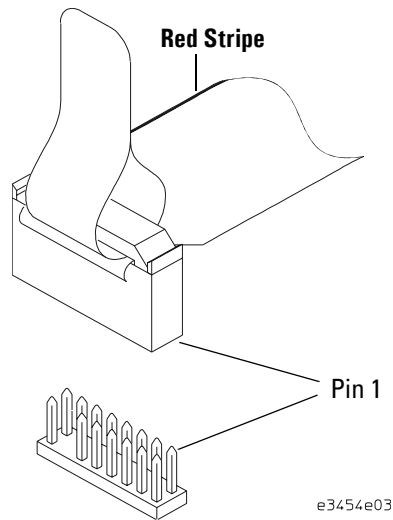

CAUTION:

Orient the red stripe *away* from pin 1 of the connector and towards the key pin. If the connector is rotated, your target system or the emulation probe may be damaged.

- 5 Turn on power to the emulation probe.
- 6 Turn on power to the target system.

After you have connected the emulation probe to your target system, you may need to update the firmware in the emulation probe.

See Also

For information on designing a debug port on your target board, see page 26.
For a list of the parts supplied with the emulation probe, see page 16.

Configuring the Emulation Probe

The emulation probe has several user-configured options. These options may be customized for specific target systems.

The easiest way to configure the emulation probe is through the Emulation Control Interface in an Agilent 16700-series logic analysis system.

For more information on starting the emulation control interface, select Help... from the emulation probe/module icon.

If you use the Emulation Control Interface, please refer to the online help in the Configuration window for information on each of the configuration options.

Other ways to configure the emulation probe are by using:

- The emulation probe's built-in terminal interface
- Your debugger, if it provides an "emulator configuration" window which can be used with this emulation probe

What can be configured

The following options can be configured using built-in commands:

- Processor type
- JTAG clock speed
- Reset operation
- Reset vector address
- Memory model
- Address translation
- Checkstop status
- Break in behavior
- Trigger out behavior
- Restriction to real-time runs
- Memory read delay
- Memory write delay
- Voltage reference
- Voltage threshold
- Memory mapped registers (MPC8260/64/65/66 only)
- To configure 32-bit mode (MPC8240 only)

The chapter concludes with a section on disabling processor caches.

Configuration items

Configuration items can be changed using the various `cf <item>` commands listed in this chapter. Configuration information is stored in non-volatile memory, so the changes you make to the emulation probe configuration will remain in effect even if you cycle power to the emulation probe.

To restore the emulation probe configuration to factory default settings, issue the `cf default` command.

To configure the processor type

Processor type configuration

Value	Emulation module configured for	Built-in command
MPC8240	Motorola MPC8240	<code>cf proc=MPC8240</code>
MPC8245	Motorola MPC8245 or MPC8241	<code>cf proc=MPC8245</code>
MPC8255	Motorola MPC8255	<code>cf proc=MPC8255</code>
MPC8260	Motorola MPC8260, MPC8264, MPC8265, or MPC8266	<code>cf proc=MPC8260</code>

To configure the JTAG clock speed (communication speed)

The emulation probe needs to be configured to communicate at a rate which is compatible with your target processor. The JTAG clock speed is independent of processor clock speed.

With some target systems that have additional loads on the JTAG lines or with target systems that do not quite meet the requirements (described in Chapter 2, “Designing a Target System for an Emulation Probe,” beginning on page 25), setting speed to a slower setting may enable the emulation probe to work.

The speed value is a number followed by either K, which indicates the value is in kHz, or M, which indicates the value is in MHz. The clock can be set to speeds in the range 512 kHz to 40 MHz. Not all values in this range are valid; if an invalid speed is entered, the next slower valid speed will be used.

Entering **cf speed** without a value will display the current JTAG clock speed.

JTAG clock speed configuration

Value	Built-in command
512K - 40M	cf speed= <i>value</i>

See Also

“Configuring the Emulation Probe for Maximum Performance” on page 67

Configuring the Emulation Probe for Maximum Performance

The performance of the emulation probe depends on the speed at which it communicates with the target system. Better performance is obtained with faster communication speeds.

Setting TCK speed

On JTAG debug ports the communication speed is controlled by the clock signal TCK. This signal is generated by the emulation probe. You can set the speed of TCK using the Emulation Control Interface in a 16700-series logic analysis system or by using the **cf speed** command through a telnet or debugger connection to the emulation probe.

To change TCK speed, send a **cf speed=x** command to the probe. To restore factory defaults, send a **cf default** command. For more information about cf speed, send a **help cf speed** command to the probe. Also note that some debuggers allow the speed to be set from within their GUI or from a command file.

When to decrease TCK speed

Emulation probes are configured at the factory with a default TCK speed. In most cases, this is equal to the maximum allowable speed as specified by the manufacturer (see the table). This speed is suitable for most applications. However, this speed is only valid if 1) the processor is running at its full rated speed, 2) trace lengths from the processor to the JTAG connector are short (two inches or less), and 3) there are no stubs on the JTAG signals. If the emulation probe cannot communicate reliably with the target system using the factory default speed, TCK speed must be reduced.

When to increase TCK speed

Some target systems will allow TCK speeds greater than the default. The real maximum speed for a given target system can be determined empirically by increasing the speed and observing if the communication to the target is reliable. However, please note that speeds greater than the default are not officially supported by Agilent or the chip manufacturer.

Configuring the Emulation Probe for Maximum Performance

Processor	Manufacturer Spec. Max TCK (MHz)	Emulation Probe Factory Default TCK (MHz)	Emulation Probe Max TCK (MHz)
MPC8240	25	20	40
MPC8241	25	20	40
MPC8245	25	20	40
MPC8255	25	20	40
MPC8260	16	10	40
MPC8264	16	10	40
MPC8265	16	10	40
MPC8266	16	10	40

To configure reset operation

The reset configuration item controls what kind of reset is performed and what state the processor will be in after the reset.

Reset configuration

Value	Effect of a reset from the emulation module	Built-in command
run	Issuing the rst command will hard reset the processor, reset the JTAG interface, and allow the processor to run. (Default)	cf reset=run
stop	Issuing the rst command will hard reset the processor, reset the JTAG interface, and cause the processor to stop at the reset exception vector 0xfff00100 or 0x00000100. The address used is determined by the config item 'vector'.	cf reset=stop

To configure reset vector address

The reset vector address configuration item specifies which reset vector the target hardware is using. This value does not set the reset vector. This is done by the hardware.

Vector address configuration

Value	Emulation module configured for	Built-in command
fff00100	Default	cf vector=fff00100
00000100		cf vector=00000100

To configure the memory model

You can use a cache coherency or a physical memory model for memory reads and writes. If both instruction and data caches are off (bits `HID0[ICE]` and `HID0[DCE]` are zero), this configuration setting has no effect and memory reads return the contents of physical memory.

Memory model configuration

Value	Meaning	Built-in command
cache	Use the cache coherency model. This model assumes instructions and data are separate, and will not occur within the same cache block (way). (Default)	<code>cf memmodel=cache</code>
physical	Use only the physical model, regardless of the state of the cache.	<code>cf memmodel=physical</code>

To configure address translation

You can enable or disable address translation in the emulation probe.

Address translation configuration

Value	Meaning	Built-in command
effective	If the MMU is enabled, addresses are verified for proper translation and the corresponding physical address is used instead. (Default)	cf address=effective
physical	Physical addresses are used, even if the MMU is enabled.	cf address=physical

When the MMU is enabled (MSR[IR] or MSR[DR] is set), and the emulation probe is configured for effective addresses, all memory addresses given to the emulation probe are assumed to be effective addresses (logical addresses). The emulation probe uses the MMU block address translation (BAT) registers, segment registers, hash tables, and other special-purpose MMU registers to compute each corresponding physical address. The requested memory operation is then performed using the physical address.

Operational notes:

- The emulation probe attempts to perform address translation only if the MSR[IR] and/or the MSR[DR] bits are set (=1) AND the emulation probe is configured to do translation (**cf address=effective**).
- If both the MSR[IR] and MSR[DR] are set, the emulation probe will perform address translations by first searching the IBAT registers and then the DBAT registers. Note that the PowerPC silicon allows the IBAT and DBAT registers to specify overlapping effective address ranges. Avoid defining overlapping ranges. These make debugging more difficult because the emulation probe can use the IBATs to translate addresses intended for the DBATs.
- If an effective address is not found in the MMU translation tables, the emulation probe will return an error and will not perform the requested operation.
- Cache coherency is maintained during emulation probe MMU translations.
- Be sure the translation enable/disable condition is the same when you set and clear breakpoints. If a breakpoint is set while translation is enabled

Configuring the Emulation Probe for Maximum Performance

and then cleared while translation is disabled, the result will be erroneous and unpredictable. This is also true if a breakpoint is set while translation is disabled and then cleared while translation is enabled.

- The emulation probe ignores read-only restrictions defined in the MMU. (In other words, the emulation probe may attempt to write to memory that has been defined by the MMU as read-only.)
- MMU translation is automatic and transparent to debuggers connected to the emulation probe.

To configure checkstop status

The checkstop signal ($\overline{\text{CSTP_OUT}}$ on pin 15 of the JTAG connector) can be used to detect a checkstop condition.

Checkstop configuration

Value	Meaning	Built-in command
off	The signal is not polled. (Default)	cf checkstop=off
on	The checkstop signal is used to detect a checkstop condition. If a checkstop condition is detected, a prompt of "c>" is returned on the command line.	cf checkstop=on

To configure the Break In SMB port

If you have an emulation probe, but you do not have an emulation module, use the following table to configure the behavior of the Break In SMB connector on the front of the emulation probe.

When the emulation probe is connected to an emulation module via the module/probe interconnect cable, this configuration item is always set to **rising** for compatibility with intermodule triggering.

If you need to break on a falling edge, either trigger from the logic analysis system or use the emulation probe without the emulation module.

Break in configuration

Value	Emulation probe Break In	Built-in command
rising	The emulation probe will cause a break into monitor on a rising edge. (Default)	cf breakin=rising
falling	The emulation probe will cause a break into monitor on a falling edge.	cf breakin=falling
off	Inputs to Break In will be ignored.	cf breakin=off

There is a delay of about 400 μ sec between receiving the edge and stopping the processor.

To configure the Trigger Out SMB port

If you have an emulation probe, but you do not have an emulation module, use the following table to configure the behavior of the Trigger Out SMB connector on the front of the emulation probe.

If you have an emulation module, the trigger out behavior is always set to **monhigh** for compatibility with intermodule triggering.

Trigger out configuration

Value	Emulation probe Trigger Out will be	Built-in command
monhigh	Logic high when the processor is running in background. (Default)	cf trigout=monhigh
monlow	Logic low when the processor is running in background.	cf trigout=monlow
fixhigh	Fixed logic high.	cf trigout=fixhigh
fixlow	Fixed logic low.	cf trigout=fixlow

To configure restriction to real-time runs

This option enables or disables restriction to real-time runs implemented for all commands other than "rst", "b", "s" and "r".

Real-time runs configuration

Value	Emulation module configured for	Built-in command
no	If the processor is running user code, a request for a register or memory display will put the processor in monitor mode, read the requested register(s), then restore the processor to running user code. (Default)	cf rrt=no
yes	If the processor is running user code, a request for a memory or register display will return: !ERROR 647! Restricted to Real Time.	cf rrt=yes

If your debugger allows displaying or modifying memory or registers while the processor is running, you must set rrt=no in order to use that feature.

To set the memory read delay

The memory read delay is provided for accessing slow devices like memory mapped IO.

The memory read delay delays all memory reads the amount of time calculated using parameters entered by the user. The user specifies the core clock frequency. The user adjusts the delay with the number of clock cycles entered.

Built-in command

```
cf mrddelcyc= <clock cycles> @ <core clock speed>
```

Example: cf mrddelcyc=300@400

This delays all reads 750 ns (300 cycles at 400 MHz).

Values

0-4000000000 clock cycles @ 100-700 MHz core clock speed.
(Default = 0 delay.)

Meaning

Delays all memory reads by the amount of time calculated from user inputs.

The number of clock cycles should be set to the smallest number possible for best performance since it delays all memory reads by the amount of time calculated.

To set the memory write delay

The memory write delay is provided for accessing slow devices like memory mapped IO.

The memory write delay delays all memory writes the amount of time calculated using parameters entered by the user. The user specifies the core clock frequency. The user adjusts the delay with the number of clock cycles entered.

Built-in command

```
cf mwrdelcyc= <clock cycles> @ <core clock speed>
```

Example: cf mwrdelcyc=300@400

This delays all writes 750 ns (300 cycles, at 400 MHz).

Value

0-4000000000 clock cycles @ 100-700 MHz core clock speed.
(Default = 0 delay.)

Meaning

Delays all memory writes by the amount of time calculated from user inputs.

The number of clock cycles should be set to the smallest number possible for best performance since it delays all memory writes by the amount of time calculated.

To configure the voltage reference

The emulation probe uses the V_{ref} signal on the JTAG connector to determine logic high and logic low levels when driving the TDI and TCK signals.

Voltage Reference Configuration

Value	Meaning	Built-in command
external	The voltage reference is generated by the target system. (Default)	cf vref=external
value	The voltage reference of <i>value</i> is generated internally by the emulation probe. The value is a number followed by either mV, which indicates the value is in millivolts, or V, which indicates the value is in volts.	cf vref= <i>value</i>

CAUTION:

This option should only be used if the core voltage is different than that of the Vref signal on the JTAG connector. Use this option with extreme care, because it is possible to damage the target system if the voltage level is chosen incorrectly.

To configure the voltage threshold

Threshold for voltage reference. Voltages above ($V_{\text{ref}} * \text{thresh}$) will be considered logic high and voltages below this level will be considered logic low.

Voltage Threshold configuration

Value	Built-in command
1/2 (Default)	cf thresh=1/2
2/3	cf thresh=2/3
1/3	cf thresh=1/3

Memory mapped registers (MPC8255 and MPC8260/64/65/66 only)

The base address of the processor's memory map is defined by the IMMR register. The target system sets the value of the IMMR at reset. You need to set the corresponding value in the emulation probe so that the emulation probe knows the location of the memory-mapped registers. Use the `cf rstimmr` configuration item to tell the emulation probe the reset value of the IMMR register.

Use a 32-bit hexadecimal value. Only the upper 16 bits are programmed into the IMMR, the lower 16 bits are read-only. The default value is `0f000000`.

Configuration register

Value	Meaning	Built-in command
value	The address value specifies the location of the memory mapped registers.	<code>cf rstimmr=address value</code>

To configure 32-bit mode (MPC8240, MPC8241, and MPC8245 only)

You can enable or disable 32-bit mode.

32-bit mode configuration

Value	Meaning	Built-in command
off	Normal, 64-bit mode. (Default)	<code>cf 32bitmode=off</code>
on	The maximum memory access size is forced to 32 bits. Do not enable this option unless it is specifically supported by your target system.	<code>cf 32bitmode=on</code>

To enable or disable processor caches

MPC82XX processors have instruction and data caches. Debugging using a third party debugger will have the greatest performance if the caches are disabled during debugging.

To turn off the caches clear bits HID0[ICE] and HID0[DCE]. This will turn off the instruction and data caches. You may need to ensure that your start up code does not enable the caches.

You may also debug with the caches enabled. To achieve maximum performance you should disable and invalidate the caches while downloading a program. You can do this by setting bits HID0[ICFI] and HID0[DCFI]. After downloading a program you may want to enable the caches by setting bits HID0[ICE] and HID0[DCE].

Performance will be slower when debugging with the caches enabled due to the emulation probe making sure the cache information stays coherent with the physical memory.

Using the Emulation Probe

Using the Emulation Probe

The emulation probe can be controlled through the following interfaces:

- A third-party debugger. This is the most practical interface to use with the emulation probe. See page 83.
- The emulation control interface of an Agilent Technologies 16700-series logic analysis system. See page 85 or 86.
- The emulation probe's command line interface. This low-level interface is generally used only for troubleshooting. See page 133.

Before you can use the Emulation Probe you must:

- 1** Connect the emulation probe to a LAN. See “Connecting the Emulation Probe to a LAN” on page 37.
- 2** Connect the emulation probe to your target system. See “To connect the emulation probe to the target system” on page 61.
- 3** Configure the emulation probe for your target system. See “Configuring the Emulation Probe” on page 63.
- 4** Confirm that the emulation probe is working with your target.

To confirm that the emulation probe can communicate with your target system, try a few simple commands using the emulation probe's command line interface. Instructions for using the command line interface are on page 133. You can read registers, read memory, or run a simple NOP loop. See page 134 and page 134 for examples.

If the emulation probe can not control the target system, see Chapter 12, “Troubleshooting the Emulation Probe,” beginning on page 123.

When using the emulation probe with a 16700-series logic analysis system, the display can be exported to a web browser, a workstation, or a personal computer (PC).

Using the Emulation Probe with a Debugger

Several prominent companies design and sell state-of-the-art source debuggers that work with Agilent emulation modules and emulation probes.

Benefits of using a debugger

The debugger will enable you to control the execution of your processor from the familiar environment of your debugger. Using a debugger lets you step through your code at the source-code level.

With a debugger connection, you can set breakpoints, single-step through source code, examine variables, and modify source code variables from the debugger interface. The debugger can also be used to download executable code to your target system.

Using a debugger to connect to the emulation probe allows the entire design team to have a consistent interface from software development to hardware/software integration.

Debugger interfaces must be ordered directly from the debugger vendor.

Compatibility with other logic analysis system tools

You can use your logic analysis system to collect and analyze trace data while you use your debugger. You can use a web browser to display the logic analyzer windows right next to your debugger.

Minimum requirements

To use a debugger with the emulation probe, you will need:

- A debugger which is compatible with the emulation probe
- A LAN connection to the PC or workstation that is running the debugger. See Chapter 4, “Connecting the Emulation Probe to a LAN,” beginning on page 37.
- A web browser or X windows or an X terminal emulator, such as Reflection X on a PC. This is required only if you wish to have the logic analysis system user interface displayed on your PC or workstation screen, along with the debugger.

Is your debugger compatible with the emulation probe?

Ask your debugger vendor whether the debugger can be used with an Agilent emulation module or emulation probe.

Compatibility with the Emulation Control Interface

CAUTION:

Do not use the Emulation Control Interface at the same time as a debugger. The Emulation Control Interface and debuggers do not keep track of commands issued by other tools. If you use both at the same time, the tools may display incorrect information about the state of the processor, possibly resulting in lost data.

Connecting to an Emulation Module

If you are using an E5901B emulation module, configure your debugger to use the IP address of the E5900B emulation probe, not the logic analysis system.

You may need to tell the debugger which port number to use. The default port number for a debugger connection is 6470.

Do not use the Emulation Control Interface at the same time as a debugger.

Using the emulation probe with a 16700-series logic analysis system via an emulation module

The following instructions explain how to control the emulation probe through an Agilent 16700-series logic analysis system which has an emulation module installed.

- 1 Select the emulation module icon in the **System** window.
- 2 Select **Connect to Emulator...** from the menu choices.

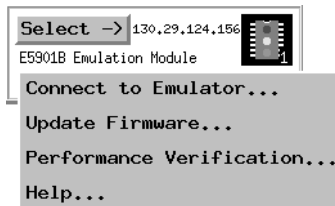

- 3 Select the **Connect to Emulator** button.

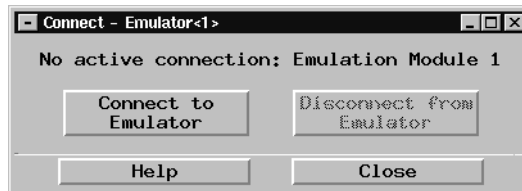

- 4 The emulation **Run Control** window will appear, which lets you use the Emulation Control Interface.



Using the emulation probe with a 16700-series logic analysis system via a LAN connection

Using the emulation probe with a 16700-series logic analysis system via a LAN connection

The following instructions explain how to use the emulation probe via a LAN connection to an Agilent 16700-series logic analysis system.

- 1 Select the emulation probe icon in the **Workspace** window.

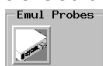

NOTE:

Use the scroll bar on the left side of the window to locate this icon.

- 2 Select **Connect to Emulator...** from the menu choices.

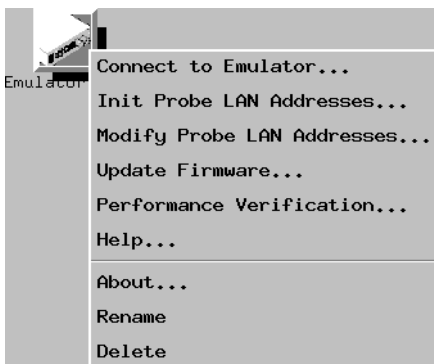

- 3 Enter the emulation probe's LAN name or IP address and select the **Connect to Emulator** button.

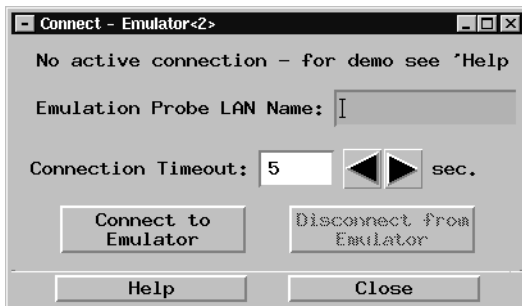

Using the emulation probe with a 16700-series logic analysis system via a LAN connection

- 4 The emulation Run Control window will appear.



Using the Emulation Probe Command Line Interface

The emulation probe has some built-in commands (also called the “terminal interface”) that you can use for troubleshooting, or to verify that you can communicate with the emulation probe. See “To use the built-in commands” on page 134.

You can enter the built-in commands using:

- A telnet (LAN) connection (see page 88).
- The Command Line window in the Emulation Control Interface of a logic analysis system (see page 89).
- A "command window" in your debugger (see your debugger software instructions).
- A serial connection (see page 42).

Establishing a telnet connection to the emulation probe prior to using the command line interface

You can establish a telnet connection to the emulation probe if:

- A host computer and the probe are both connected to a local-area network (LAN), and
- The host computer has the telnet program (often part of the operating system or an internet software package).

To establish a telnet connection:

- 1** Find out the LAN address or LAN name of the emulation probe.
- 2** Start the telnet program.

If the LAN name of the emulation probe is “test2”, the command might look like this:

```
telnet test2
```

- 3** If you do not see a prompt, press the <Return> key a few times.

To exit from this telnet session, type <CTRL>D at the prompt.

Using the command line interface from the logic analysis system

- 1 Connect to the emulator. See “Using the Emulation Probe” on page 81 for step-by-step instructions.
- 2 From the Run Control menu bar select **Window**, then select the emulator, and select **Command Line...**

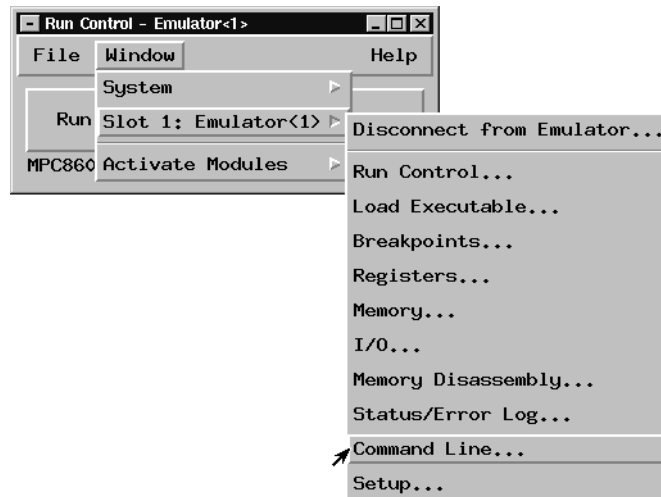

- 3 The command line window will be displayed. You can enter commands in the “Command Input” field of the Command Line window.

Exporting the Logic Analysis System's Display

The Agilent 16700-series logic analysis system's display can be exported to:

- A web browser
 - A workstation
 - A personal computer
-

To export the logic analysis system's display to a web browser

You can export the display of an Agilent 16700-series logic analysis system to your PC or workstation using a web browser. See the online help in your logic analysis system for more information.

To export the logic analysis system's display to a UNIX workstation

By exporting the logic analyzer's display, you can see and use the logic analysis system's windows on the screen of your workstation. To do this, you must have telnet software and X window installed on your computer.

- 1 On the workstation, add the host name of the logic analysis system to the list of systems allowed to make connections:

```
xhost +<IP_address>
```

- 2 Use telnet to connect to the logic analysis system.

```
telnet <IP_address>
```

- 3 Log in as "logic".

The logic analysis system will open a Session Manager window on your display.

- 4 In the Session Manager window, select **Start Session on This Display**.
-

Example

On a UNIX workstation, you could use the following commands to export the display of a logic analysis system named “mylogic”:

```
$ xhost +mylogic
$ telnet mylogic
Trying...
Connected to mylogic.mycompany.com.
Escape character is '^]'.
Local flow control on
Telnet TERMINAL-SPEED option ON

Agilent Logic Analysis System
Please Log in as: logic [displayname:0]
login: logic
Connection closed by foreign host.
```

To export the logic analysis system's display to a PC

By exporting the logic analyzer's display, you can see and use the logic analysis system's windows on the screen of your PC. To do this, you must have telnet software and an X terminal emulator installed on your computer. The following instructions use the Reflection X emulator from WRQ, running on Windows 95, as an example.

- 1 On the PC, start the X terminal emulator software.

To start Reflection X, select the Reflection X Client Startup icon.

- 2 Start a telnet connection to the logic analysis system.

Log in as “logic”.

For Reflection X, enter the following values in the Reflection X Client Startup dialog:

- a In the Host field, enter the LAN name or IP address of the logic analysis system.
- b In the **User Name** field, enter “logic”.
- c Leave the **Password** field blank.
- d Leave the **Command** field blank.
- e Select **Run** to start the connection.

The logic analysis system will open a Session Manager window on your display.

Chapter 8: Using the Emulation Probe
Exporting the Logic Analysis System's Display

- 3** In the Session Manager window, select **Start Session on This Display**.

Testing Target System Memory

Two ways to run the memory tests

Many times when a system under test fails to operate as expected, you will need to determine whether the failure is in the hardware or the software. These tests verify operation of the memory hardware in the system under test.

Two ways to run the memory tests

There are two methods for accessing and running the emulation probe's built-in memory tests:

- Through the Emulation Control Interface of a 16700-series logic analysis system
- Using a command line interface (also called terminal interface)

You can use the command line interface through a terminal emulator or through a command window in your debugger.

Using the memory tests with an Agilent 16700 logic analysis system

- 1 Connect to the emulator. See “Using the Emulation Probe” on page 82 for step-by-step instructions.
- 2 From the menu bar select **Window**, then select the emulator, and select **Memory...**

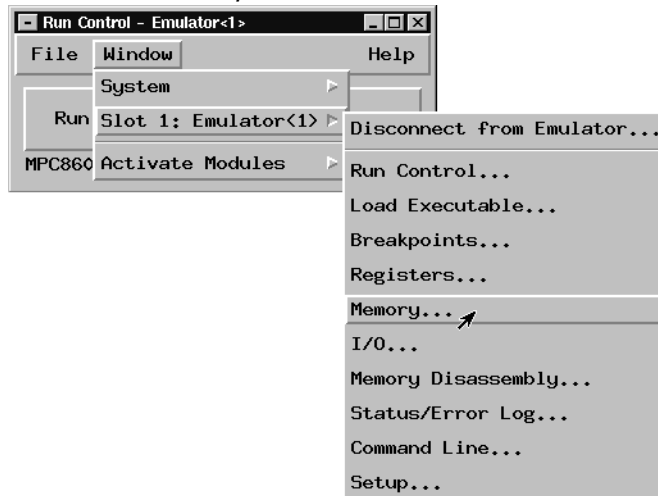

- 3 Select the **Memory Test...** button and set up the test in the window that appears.

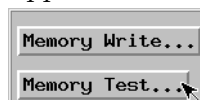

- 4 Select the test type and set the parameters in the window that appears.
- 5 For help using the memory tests select **Help** from the menu bar, then select **On This Window**.

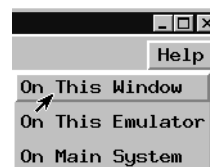

Using the memory tests from a command line interface

You can use the memory tests from a command line interface via a telnet session or via the emulator command window of your debugger. You can initiate a telnet connection by issuing a telnet to the emulation probe's IP address from a terminal window.

See Chapter 4, "Connecting the Emulation Probe to a LAN," beginning on page 37 for instructions on making a connection to the emulation probe which will allow you to access the emulation probe via a command line interface.

For general memory test syntax information, enter the following command at the emulation probe command line interface:

```
help mtest
```

This will display the following help dialog:

```
mtest - memory test      General Help:

mtest bp [-a1/2/4/8] [-v1-4] [-r1] <start>[..

```

Memory Test Patterns

You can use the memory test feature of the emulation probe to perform seven different types of tests. Use these tests to find problems in address lines, data lines, and data storage. Use these tests in combination because no single test can perform a complete evaluation of the target system memory.

The emulation probe provides the following memory tests:

- Basic Pattern - to validate data read-write lines.
- Address Pattern - to validate address read-write lines.
- Rotate Pattern - to validate data read-write lines, and test voltage and ground bounce.
- Walking Ones - to validate individual storage bits in memory.
- Walking Zeros - to validate individual storage bits in memory.
- Oscilloscope Read - to generate the signals associated with reading from memory so they can be viewed on an oscilloscope.
- Oscilloscope Write - to generate the signals associated with writing to memory so they can be viewed on an oscilloscope.

Recommended Test Procedure

Two types of tests are offered for testing target memory: oscilloscope tests, and memory functionality tests.

Oscilloscope Tests

1. Connect the oscilloscope to view activity on the bits of interest.
2. Start an Oscilloscope Read (see page 108) or Oscilloscope Write (see page 109) test, as desired.

The test activity will be written onto the bits you specified continuously until you cancel the test.

Use both the Oscilloscope Read test and the Oscilloscope Write test to thoroughly check the connections of interest.

Memory Functionality Tests

1. Run the Basic Pattern (see page 99) test on the entire Memory Range.
Result:
 - No Problems. Perform the Address Pattern (see page 102) test next.
 - Problems found. Refer to “If problems were found by the Basic Pattern test” on page 100.
2. Run the Address Pattern (see page 102) test on the entire Memory Range.

Result:

- No Problems.
- Problems found. Refer to “If problems were found by the Address Pattern test” on page 103.

If no problems were found by the Basic Pattern test and the Address Pattern test above, you can ignore the rest of the tests. The memory in your system has been tested thoroughly and it is good.

Basic Pattern test

The Basic Pattern test finds data bits in the specified memory range that are stuck high or low. It also detects data lines that may be tied to power, ground, or not connected at all.

How the Basic Pattern test works

This test writes the *Pattern* and the complement of the *Pattern* to the *Memory Range*, and then compares the values in memory with what was written. The complement of the *Pattern* and then the *Pattern* are then written, read, and compared.

Example:

Entering the command

```
mtest bp -a4 -v1 -r2 20000000..20000000f=55555555
```

will produce the following memory writes and reads:

	First Write/Read	Second Write/Read
20000000	55555555	AAAAAAAA
20000008	AAAAAAAA	55555555

If no errors were found, the following output would appear on your screen:

```
M>mtest bp -a4 -v1 -r2 20000000..20000000f=55555555  

Starting: Basic Pattern Test  

Completed: Basic Pattern Test  

Summary: 2 - PASSED
```

Instructions for using the Basic Pattern test

For help about performing a specific memory test using the Agilent 16700-series logic analysis system, see page 95.

To use the Basic Pattern test from the command line interface, enter **mtest bp <parameters>**. To see a list of the required parameters, enter **? mtest bp**.

For general instructions on using the command line interface see page 88.

Memory Test Patterns**Interpreting Basic Pattern test results**

Consistent errors such as a particular bit incorrect every four bytes typically indicate a problem with the data lines. Random or sparse errors may indicate hardware data memory errors—check individual locations with the Walking Ones and Walking Zeros tests.

This test will halt and generate an error message if your Memory Range specification causes this test to be performed outside the range of valid memory in your target system.

This test will not halt but it will generate an error message if it is run on ROM or on locations with data line or location errors.

You can open a memory window on your logic analyzer to view the memory content. Expect to see the pattern and the complement of the pattern that was specified.

This test will not always detect errors in the address lines. For example, if a bit in the address lines is stuck high or low, the Pattern Test will write to a different location in memory. Then the read from memory for comparison will also be made from that different location so the data will be correct. Use the Address Pattern test with this test to completely evaluate the memory range.

If problems were found by the Basic Pattern test

Below are two examples of problems found by the Basic Pattern test.

Example 1: Consistent error

```
Starting: Basic Pattern Test
Error: 1 at address 00000200:
  Read      5557 (0101 0101 0101 0111)
  Expected  5555 (0101 0101 0101 0101)
Error: 2 at address 00000204:
  Read      5557 (0101 0101 0101 0111)
  Expected  5555 (0101 0101 0101 0101)
Error: 3 at address 00000208:
  Read      5557 (0101 0101 0101 0111)
  Expected  5555 (0101 0101 0101 0101)
Error: ...
  Read      ...
  Expected  ...
```

Assume the data line bit associated with the error is stuck high. This could happen if the suspected data line bit were soldered to power.

For an additional test of suspected memory, perform the Walking Ones (see page 106) and Walking Zeros (see page 107) tests on the problem memory range.

Example 2: Random errors

```
Starting: Basic Pattern Test
Error: 1 at address 00000200:
  Read      8000  (1000 0000 0000 0000)
  Expected  0000  (0000 0000 0000 0000)
Error: 2 at address 000004a2:
  Read      efff  (1110 1111 1111 1111)
  Expected  ffff  (1111 1111 1111 1111)
Repetition: 1 - FAILED found 2 errors
Completed: Basic Pattern Test
Summary: 1 of 1 - FAILED (2 errors total)
```

From the above listing, we assume there are two location errors in memory. At location 200, there is a bit stuck high. At location 4a0, there is bit stuck low. Use the Walking Ones and Walking Zeros tests to verify the errors.

There is one bit stuck high at location 200 so the Walking Zeros test will print one error message when it tests this location. Use the Walking Ones test to isolate the bit that is stuck low at location 4a0. Again, this will print only one error message.

Address Pattern test

This test verifies that the address lines of the selected memory range are without error.

How the Address Pattern test works

This test writes the address of each memory location as data to each location. The data is then read back to see if it matches the address.

The pattern written to the memory is generated at the start of the test and is dependent upon the start address, access size, and the number of bytes in the memory range.

Depending on the last *Access Size* selected, subsets of the addresses may be written to memory.

Example:

If the last access size was 1 byte, address 00000001 will have 01 written to it, and address 00000002 will have 02 written to it.

The data written in address 00001000 will look like this, depending on the last *Access Size*.

```

1 Byte = 00001000  00 01 02 03 04 05 06 07 08 09 0a 0b 0c 0d 0e 0f
2 Byte = 00001000  1000 1002 1004 1006 1008 100a 100c 100e
4 Byte = 00001000  00001000 00001004 00001008 0000100c
8 Byte = 00001000  00000000000001000 0000000000001008

```

The upper four bytes of an 8 Byte access size are not tested for a 4 Byte address. The upper four bytes will always be zeros. Use a smaller access size to test these locations with the Address Pattern test.

Unless the access size is 1 Byte, the odd bits of the memory locations will not be tested. Use the Basic Pattern test to check the odd bits.

Instructions for using the Address Pattern test

For help about performing a specific memory test using the Agilent 16700-series logic analysis system, see page 95.

To use the Address Pattern test from the command line interface, enter **mtest ap <parameters>**. To see a list of the required parameters, enter

? mtest ap.

For general instructions on using the command line interface see page 88.

Interpreting Address Pattern test results

This test does not ensure that the data lines or individual data locations are without error. If a bit is stuck in a memory location, but is stuck in the written value, the stuck bit will not be detected.

You can view the memory in an analyzer memory window of a 16700-series logic analysis system by selecting **Window <emulator> Memory...** Enter ? m at the command line prompt for help viewing memory using a terminal interface. You should see direct correlation between each address and the data stored at that address.

Consistent errors typically indicate problems in the address lines. This is especially likely if the results of the Basic Pattern test were without errors.

Errors in specific memory locations may indicate errors in the memory hardware instead of the address lines.

If problems were found by the Address Pattern test

You may see no errors in the Basic Pattern test, but errors in the Address Pattern test. For example, you might see the following result in the Address Pattern test:

Example:

```
Error: 1 at address 00000000:
  Read      0020  (0000 0000 0010 0000)
  Expected  0000  (0000 0000 0000 0000)
Error: 2 at address 00000002:
  Read      0022  (0000 0000 0010 0010)
  Expected  0002  (0000 0000 0000 0010)
```

You would see that the data stored at locations 00 through 0f is the data that should be at locations 20 through 2f. This indicates an address line problem. Address bit 5 must be stuck low because the addresses that should have been written to the range 20 through 2f were written instead to 00 through 0f.

Random errors typically do not indicate address line errors. Use the Walking Ones (see page 106) and Walking Zeros (see page 107) tests to check the locations of random errors.

Rotate Pattern test

The Rotate Pattern test finds data bits in memory that are stuck high or low. It also detects data lines that may be tied to power ground, or not connected at all. This test can be used to test voltage and ground bounce problems associated with the selected memory range.

How the Rotate Pattern test works

This test writes the *Pattern* and the complement of the *Pattern* to the *Memory Range*, and then compares the values in memory with what was written. Next, the rotated *Pattern* and the rotated complement of the *Pattern* are written, read, and compared. Now the *Pattern* is rotated again, and again it is written, read, and compared. This continues until the rotations of the pattern return it to its original arrangement. That constitutes one *Repetition* of the Rotate Pattern test.

Example:

Address	First Write/Read	Second Write/Read	Third Write/Read
00000000	01	FE	02
00000001	FE	02	FD
00000002	02	FD	04
00000003	FD	04	FB
00000004	04	FB	08
00000005	FB	08	F7
00000006	08	F7	10
00000007	F7	10	EF
00000008	10	EF	20

Larger *Access Size* selections take more time because they require more patterns to be written to all locations (2-byte *Access Size* requires writing 32 patterns, and 4-byte *Access Size* requires writing 64 patterns).

The *Access Size* you select will affect the appearance of memory when you view memory after a test. When a test is complete, memory contains the last set of patterns that was written to it.

Example:

The following listing is from a Rotate Pattern test which was performed one time with an *Access Size* of 2 bytes, and an initial pattern of 0001.

What you see below is the 32nd set of patterns written to memory during the test.

```
00000000  7fff 0001 fffe 0002 fffd 0004 fffb 0008
00000010  fff7 0010 ffef 0020 fdfd 0040 fbf7 0080
00000020  ff7f 0100 feff 0200 fdff 0400 fbff 0800
00000030  f7ff 1000 efff 2000 dfff 4000 bfff 8000
00000040  7fff 0001 fffe 0002 fffd 0004 fffb 0008
00000050  fff7 0010 ffef 0020 fdfd 0040 fbf7 0080
00000060  ff7f 0100 feff 0200 fdff 0400 fbff 0800
00000070  f7ff 1000 efff 2000 dfff 4000 bfff 8000
```

Instructions for using the Rotate Pattern test

Since the Rotate Pattern test is designed to rotate a single bit through memory, it is generally best to use a pattern such as 01, 0001, or 00000001.

For help about performing a specific memory test using the Agilent 16700-series logic analysis system, see page 95.

To use the Rotate Pattern test from the command line interface, enter **mtest rp <parameters>**. To see a list of the required parameters, enter **? mtest rp**.

For general instructions on using the command line interface see page 88.

Interpreting Rotate Pattern test results

You can open a memory window on your logic analyzer to view the memory content. Expect to see the pattern and the complement of the pattern that was specified.

Consistent errors such as a particular bit incorrect every four bytes typically indicate a problem with the data lines. Random or sparse errors may indicate hardware data memory errors—check individual locations with the Walking Ones and Walking Zeros tests.

This test will halt and generate an error message if your Memory Range specification causes this test to be performed outside the range of valid memory in your target system.

Memory Test Patterns

This test will not halt but it will generate an error message if it is run on ROM or on locations with data line or location errors.

Walking Ones test**How the Walking Ones test works**

The Walking Ones test finds data bits stuck in logical "0". This test cycles "1" through each bit position in memory, and checks results. It does this by writing and then reading a pattern sequence of ones and zeros from all memory locations in the range.

Example:

The hexadecimal values 01, 02, 04, ... are written to each location in the *Memory Range*.

Address	1st	2nd	3rd	4th	5th	6th	7th	8th
00000000	01	02	04	08	10	20	40	80
00000001	02	04	08	10	20	40	80	01
00000002	04	08	10	20	40	80	01	02
00000003	08	10	20	40	80	01	02	04
00000004	10	20	40	80	01	02	04	08

1st, 2nd, 3rd, etc. are the first, second, third, etc. complete passes through the memory.

Larger *Access Size* selections take more time because they require more patterns to be written to all locations (2-byte *Access Size* requires writing 16 patterns, and 4-byte *Access Size* requires writing 32 patterns).

Example:

2-byte Access Size writing 16 patterns:

Address	1st	2nd	3rd	4th	5th	6th	7th	8th	9th	...	16th
00000000	0001	0002	0004	0008	0010	0020	0040	0080	0100	...	8000
00000001	0002	0004	0008	0010	0020	0040	0080	0100	0200	...	0001
00000002	0004	0008	0010	0020	0040	0080	0100	0200	0400	...	0002
00000003	0008	0010	0020	0040	0080	0100	0200	0400	0800	...	0004
00000004	0010	0020	0040	0080	0100	0200	0400	0800	1000	...	0008

Instructions for using the Walking Ones test

For help about performing a specific memory test using the Agilent 16700-

series logic analysis system, see page 95.

To use the Walking Ones test from the command line interface, enter **mtest w1 <parameters>**. To see a list of the required parameters, enter **? mtest w1**.

For general instructions on using the command line interface see page 88.

Walking Zeros test

The Walking Zeros test finds data bits stuck in logical "1".

How the Walking Zeros test works

This test cycles "0" through each bit position in memory, and checks results.

Example:

The hex values FE, FD, FB, ... are written to each location in the *Memory Range*.

Address	1st	2nd	3rd	4th	5th	6th	7th	8th
00000000	FE	FD	FB	F7	EF	DF	BF	7F
00000001	FD	FB	F7	EF	DF	BF	7F	FE
00000002	FB	F7	EF	DF	BF	7F	FE	FD
00000003	F7	EF	DF	BF	7F	FE	FD	FB
00000004	EF	DF	BF	7F	FE	FD	FB	F7

1st, 2nd, 3rd, etc. are the first, second, third complete pass through the memory.

Larger *Access Size* selections take more time because they require more patterns to be written to all locations (2-byte *Access Size* requires writing 16 patterns, and 4-byte *Access Size* requires writing 32 patterns).

Example:

2-byte Access Size writing 16 patterns:

Address	1st	2nd	3rd	4th	5th	6th	7th	8th	9th	...	16th
00000000	FFFE	FFFD	FFFB	FFF7	FFEF	FFDF	FFBF	FF7F	FEFF	...	7FFF
00000001	FFFD	FFFB	FFF7	FFEF	FFDF	FFBF	FF7F	FEFF	FDFF	...	FFFE
00000002	FFFB	FFF7	FFEF	FFDF	FFBF	FF7F	FEFF	FDFF	FBFF	...	FFFD
00000003	FFF7	FFEF	FFDF	FFBF	FF7F	FEFF	FDFF	FBFF	F7FF	...	FFFB
00000004	FFEF	FFDF	FFBF	FF7F	FEFF	FDFF	FBFF	F7FF	FEFF	...	FFF7

Instructions for using the Walking Zeroes test

For help about performing a specific memory test using the Agilent 16700-series logic analysis system, see page 95.

To use the Walking Zeroes test from the command line interface, enter **mtest w0 <parameters>**. To see a list of the required parameters, enter **? mtest w0**.

For general instructions on using the command line interface see page 88.

Oscilloscope Read test

How the Oscilloscope Read test works

This test repetitively reads the present content from the *Memory Range* for the number of *Repetitions* specified, typically reads continuously until cancelled.

NOTE:

The Oscilloscope Read test does not print or store the data it has read. It is usually used to perform timing analysis on target system memory.

Instructions for using the Oscilloscope Read test

Connect your oscilloscope to view signals on the lines to be tested. These will be the signals generated to perform read transactions from the memory in your target system.

When you have finished using your oscilloscope to view the read-from-memory signals:

- If you are using a 16700 logic analysis system, select the *Cancel* button in the *Busy* dialog box.
- If you are using the command line interface, press Ctrl+C.

You will see an error message if your test attempts to read memory addresses outside the range of available memory.

For help about performing a specific memory test using the Agilent 16700-series logic analysis system, see page 95.

To use the Oscilloscope Read test from the command line interface, enter **mtest or <parameters>**. To see a list of the required parameters, enter **? mtest or help mtest**. For general instructions on using the command

line interface see page 88.

Oscilloscope Write test

How the Oscilloscope Write test works

This test repetitively writes your selected *Pattern* to the *Memory Range* for the number of *Repetitions* specified, typically continuously until cancelled.

If your pattern is larger than the access size, it will be truncated to fit. If your pattern is smaller than the access size, it will be zero-padded to fit.

This test does not generate error messages for unsuccessful write transactions, such as writes to ROM. This test is usually used to perform timing analysis on target system memory.

If desired, you can open a memory window in the logic analyzer and view the memory where the pattern was written. If the memory is ROM or if it contains errors, it may not contain the pattern that was written.

Instructions for using the Oscilloscope Write test

Connect your oscilloscope to view signals on the lines to be tested. These will be the signals generated to perform write transactions to the memory in your target system.

When you have finished using your oscilloscope to view the write-to-memory signals:

- If you are using a 16700 logic analysis system, select the *Cancel* button in the *Busy* dialog box.
- If you are using the command line interface, press Ctrl+C.

You will see an error message if your test attempts to write to memory addresses outside the range of available memory.

For help about performing a specific memory test using the Agilent 16700-series logic analysis system, see page 95.

To use the Oscilloscope Write test from the command line interface, enter **mtest ow <parameters>**. To see a list of the required parameters, enter **? mtest ow**.

For general instructions on using the command line interface see page 88.

Chapter 9: Testing Target System Memory
Memory Test Patterns

Updating Firmware

Chapter 10: Updating Firmware

Firmware gives your emulation probe a “personality” for a particular processor or processor family. The MPC82XX firmware is compatible with all of the processors listed on page 4. You do not have to install new firmware when you decide to control a different processor in the MPC82XX family.

After you have connected the emulation probe to your target system, you may need to update the firmware to give it the right personality for your processor.

Update the firmware if:

- You need to change the personality of the emulation probe for a new processor.
- You have an updated version of the firmware from Agilent Technologies.

Updating Firmware When Operating With a Debugger

To display current firmware version information

- Use `telnet` to access the built-in "terminal interface" and use the `ver` command to view the version information for firmware currently in the emulation probe.

To update firmware from the web

To update the firmware, you must have access to the World Wide Web and a PC or a workstation connected to your emulation probe (through a LAN).

- 1 Download the new firmware from the World Wide Web site at:
<http://www.cos.agilent.com/probe>
- 2 Follow the instructions on the web site for installing the firmware.

To update firmware from a floppy disk

- Follow the instructions on the README file on the floppy disk.

The firmware can be installed using either a PC or a workstation which can read PC disks.

Updating Firmware With a Logic Analysis System

Always update firmware by installing a processor support package. This will ensure that the version of the Emulation Control Interface software is compatible with the version of the emulation probe firmware. Logic analysis system operating system CD-ROMS include the processor support packages; versions 1.51 and later will include firmware which is compatible with E5900B emulation probes.

To display current firmware version information

- 1 Open the Update Firmware window.

For an emulation module: In the system window, select the emulation module and select **Update Firmware...**

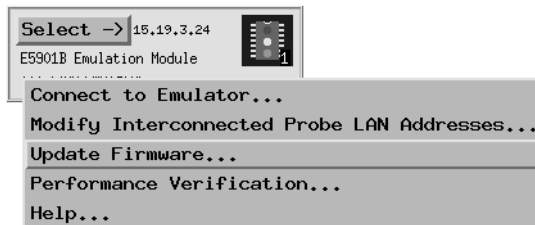

For an emulation probe: In the Workspace window, drag the emulation probe icon onto the workspace then select **Update Firmware...**



- 2 In the Update Firmware window, select **Display Current Version**.

There are usually two firmware version numbers: one for “Generics” and one for the personality of your processor.

To update firmware using the Emulation Control Interface

- 1 End any run control sessions which may be running.
- 2 Install the processor support package from the CD-ROM, if necessary.
- 3 Open the Update Firmware window.

For an emulation module: In the system window, select the emulation module and select **Update Firmware...**

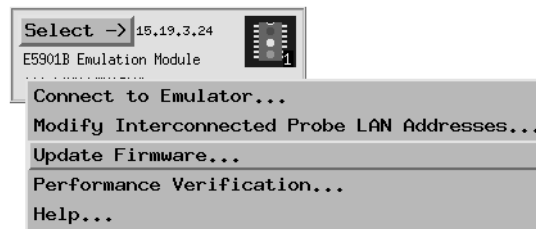

For an emulation probe: In the Workspace window, drag the emulation probe icon onto the workspace then select **Update Firmware...**

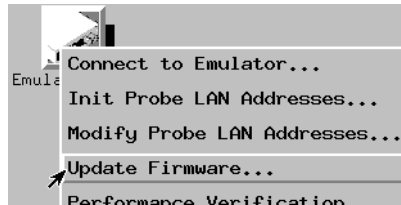

- 4 In the Update Firmware window, select the firmware to load into the emulation module.
- 5 Select **Update Firmware**.

In about 80 seconds, the firmware will be installed and the screen will update to show the current firmware version.

See also

“Installing Software” beginning on page 53 for instructions on how to install the processor support package from the CD-ROM.

To update firmware for an emulation probe using the Setup Assistant

The Setup Assistant is an online tool for connecting and configuring your logic analysis system for microprocessor and bus analysis. The Setup Assistant is available on Agilent 16700-series logic analysis systems.

This menu-driven tool will guide you through the connection procedures for connecting the logic analyzer to an analysis probe, an emulation probe, or other supported equipment. It will also guide you through connecting an analysis probe to the target system.

- 1 Install the processor support package from the CD-ROM.
- 2 Start the Setup Assistant by selecting its icon in the system window.



- 3 Follow the instructions displayed by the Setup Assistant.

See also

Page 56 for instructions on how to install a the processor support package from the CD-ROM.

Installing an Agilent E5902B
Emulation Migration Kit

This chapter shows you how to install an Agilent E5902B emulation migration so that you can use your emulation probe with a new processor family.

The E5902B emulation migration can be used with any E5900B emulation probe. It cannot be used with E5900A emulation probes.

Will I need to change the target board adapter?

A target board adapter is supplied with the emulation migration. Some target board adapters are compatible with more than one type of processor.

Use the table below to determine the part number of the target board adapter that you already have. Then use the table to determine the part number of the target board adapter for the processor type that you are migrating to. If the part numbers are the same, you don't need to change the target board adapter.

Processor Type	Use target board adapter	Emulation Migration P/N
MPC6XX	E8130-66503	Agilent E5902B Option 060
MPC7XX	E8130-66503	Agilent E5902B Option 070
MPC8XX	E8130-66508	Agilent E5902B Option 080
M•CORE	E8130-66515	Agilent E5902B Option 090
MPC82XX	E8130-66503	Agilent E5902B Option 100
MPC74XX	E8130-66503	Agilent E5902B Option 110
MIPS32/MIPS64	E8130-66516	Agilent E5902B Option 200
ARM7/ARM9	E8130-66504	Agilent E5902B Option 300

Steps 4 through 7 of the procedure that follows show how to replace the target board adapter.

If you don't need to replace the target board adapter, proceed to Chapter 10, "Updating Firmware," beginning on page 111.

To install the emulation migration

CAUTION:

Electrostatic discharge can damage electronic components. Use grounded wrist straps and mats.

The tools necessary for this procedure are supplied with the emulation migration kit.

- 1 Turn off power to the emulation probe.
- 2 Disconnect all cables from the emulation probe, including the power cord, LAN cable, serial cable, module/probe interconnect cable, and target cable.
- 3 Remove the cover from the emulation probe:
 - a Remove the 2 nuts and 2 screws from the front of the emulation probe.

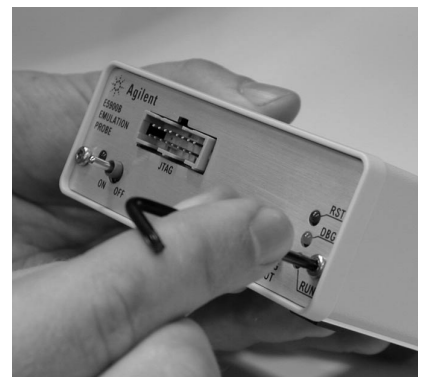
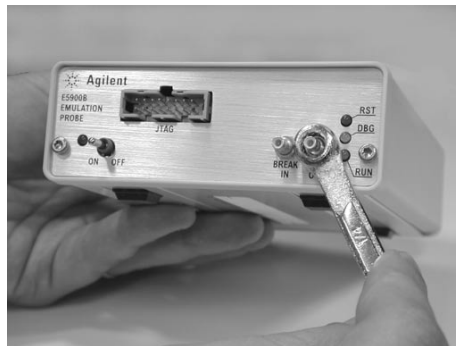

- b** Remove the front panel.

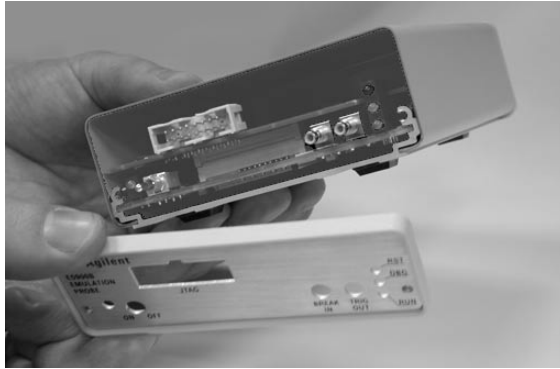

- c** Grasp the top cover with one hand. With the other hand, pull the plate on the bottom of the emulation probe, so that the top cover slides off.



- 4 Remove the 3 nylon screws from the target board adapter.

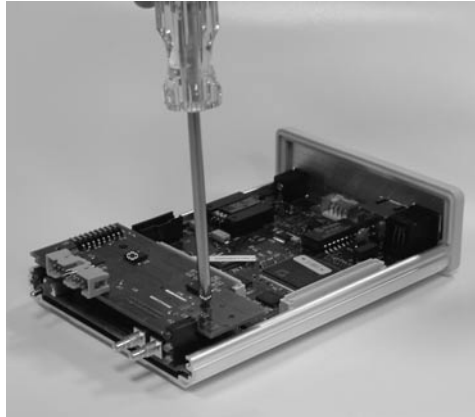

- 5 Carefully lift the target board adapter from the main circuit board.

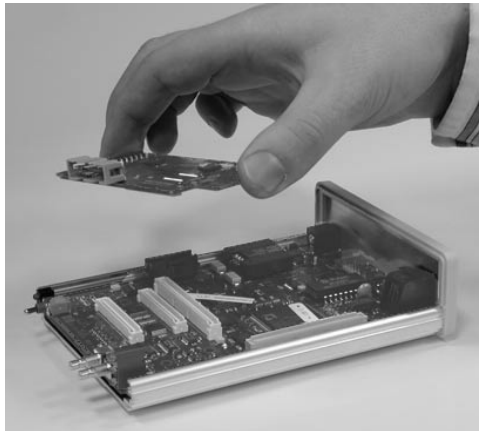

Do not turn on power to the emulation probe when no target board adapter is installed.

You cannot run performance verification tests or make any measurements without a target board adapter.

- 6 Install the new target board adapter on the main circuit board.
Align both connectors and press down firmly.
- 7 Replace the 3 nylon screws.

8 Reinstall the cover on the emulation probe:

- a** Slide the top cover into place.
- b** Assemble the new front panel.

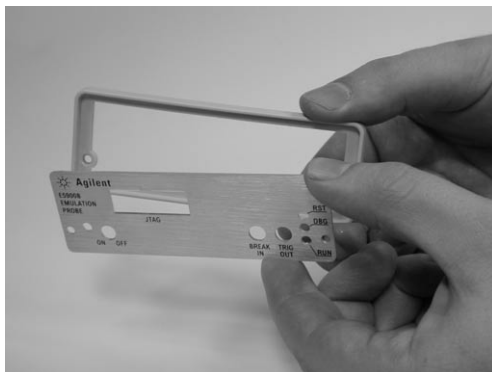

c Attach the front panel using the 2 screws and 2 nuts.

9 Connect the LAN cable, module/probe interconnect cable (if you will be using the emulation probe with an emulation module), and the LAN cable to the emulation probe. Do not connect a target cable yet.

10 Turn on power to the emulation probe.

11 Update the emulation probe's firmware.

See Chapter 10, "Updating Firmware," beginning on page 111 for instructions on how to update firmware.

12 Run the performance verification test.

See page 156 for instructions on testing the emulation probe.

13 Connect the emulation probe to your target system.

See Chapter 6, "Connecting the Emulation Probe to Your Target System," beginning on page 59 for instructions on how to make this connection.

Troubleshooting the Emulation Probe

Chapter 12: Troubleshooting the Emulation Probe

If you have problems with the emulation probe, your first task is to determine the source of the problem. Problems may originate in any of the following places:

- The connection between the emulation probe and your debugger
- The emulation module or emulation probe itself
- The connection between the emulation probe and the target system
- The target system

You can use several means to determine the source of the problem:

- The troubleshooting guide beginning on the next page
- The status lights on the emulation probe
- The emulation probe performance verification (PV) tests
- The emulation probe's built-in commands

The information in this chapter is presented in the following sections:

- General Troubleshooting
- Status Lights
- Emulation Probe Built-in Commands
- Problems with the Target System
- Problems with the LAN Interface
- Problems with the Serial Interface
- Problems with the Emulation Module
- Problems with the Emulation Probe
- Using the Emulation Probe Terminal Interface
- Returning Parts for Service

General Troubleshooting

If you have trouble using the emulation probe, the following steps may help you identify the problem. This troubleshooting procedure uses the built-in command line interface. For more information on the command line interface, see page 133.

Step 1: Telnet to the emulation probe

Use telnet to connect to the emulation probe across the LAN. (For instructions on how to do this, see “Verifying LAN Communications” on page 51.)

The emulation probe must be reachable via LAN before you can use it.

If you cannot connect to the emulation probe

If you cannot ping or telnet to the emulation probe:

- See “Problems with the LAN Interface” on page 150.
 - If you need to change the LAN parameters of the emulation probe, see Chapter 4, “Connecting the Emulation Probe to a LAN,” on page 37.
-

Step 2: Check the prompt

Once you have connected to the emulation probe, press the Enter key a few times and look at the prompt which is displayed.

If a telnet connection to the emulation probe displays the prompt "->"

The "->" prompt indicates that the firmware loaded into the emulation probe is not compatible with the "target board adapter" which is located inside the emulation probe.

General Troubleshooting

Try one of the following until you get a different prompt:

- Cycle power on the emulation probe. (Turn off your target power first.)
- Check that the proper firmware is installed for the target board adapter or the type of emulation probe shown on the front panel of the emulation probe.

The proper firmware is installed at the factory but it could accidentally be changed. A "ver" command will display the firmware which is currently loaded. Refer to "Updating Firmware" on page 111 if the firmware is incorrect.

- Run the performance verification tests. Refer to "To run the emulation probe performance verification tests" on page 156.

Connection to the wrong target or connection to the target with the pins connected backward could potentially damage the emulation probe. Use the performance verification tests to validate that the emulation probe itself is working correctly.

If a telnet connection to the emulation probe displays the prompt "?>"

The "?>" prompt indicates that the emulation probe is having trouble talking to the target and it doesn't know what state the target is in.

- Validate that the emulation probe is connect to a powered up target.

Refer to Chapter 6, "Connecting the Emulation Probe to Your Target System," beginning on page 59.

- Check the emulation probe configuration settings.

Enter the **cf** command to display the configuration settings. Note that some emulation probes must set the processor type with **cf proc=processor_type**.

- Decrease the JTAG communication speed. Some targets need slower speeds to properly communicate.

Use the **cf speed** command.

- Check that the proper firmware is installed for this processor.

See Chapter 10, "Updating Firmware," beginning on page 111.

Step 3: Try some simple commands to control the target

Examples of some commands are listed on page 134.

If the emulation probe has problems controlling the target

The emulation probe might be having problems controlling the target if you see messages such as:

```
"Cannot break"  
"Processor is checkstopped"  
"Bad status code (0xff) received from the processor"
```

Or the prompt changes to "?>"

Problems controlling the target can be caused by a variety of conditions. Typically the problem is in the configuration of the emulation probe or the configuration of the target.

Try the following to better control your target:

- Check that the JTAG signals are being driven properly.

In particular, if your processor requires the $\overline{\text{QACK}}$ signal to be low, and the signal is not low, the emulation probe will not be able to control the processor. See page 26.

- Decrease the JTAG communication speed. Some targets need slower speeds to properly communicate.

If you are using a telnet connection or a debugger command file, use the **cf speed** command.

- Check the emulation probe configuration settings.

If you are using a telnet connection, enter the **cf** command to display all of the configuration settings.

Pay particular attention to the **cf proc=processor_type** line of the output. If you need to change the processor type, you must load the appropriate firmware into the emulation probe (See “Updating Firmware” on page 111.).

General Troubleshooting

- Check that the emulation probe is not restricted to real-time runs.

If you are using a telnet connection or a debugger command file, use the **cf rrt=no** command.

Restrict to real time will not allow you to access memory or registers while the target is running. By setting this option to no, you will be able to access the memory and registers while the target is running.

- Check that the target processor is configured.

Some target require configuration registers on the processor to be initialized before the emulation probe can properly communicate with the target.

For example, the MPC860 requires memory chip selects to be defined before the target memory can be accessed. Other processors need their memory controllers initialized.

To initialize the target processor, either run your target from reset (if you have a BOOT ROM) or define a series of emulation probe commands to initialize the target.

Also refer to “Using the Emulation Probe Command Line Interface” on page 133 for additional information about testing a target.

Step 4: Check the emulation module

If you are using an E5901B emulation module, select the emulation module icon and start the Emulation Control Interface.

If you have problems using the emulation probe as an emulation module in a 16700-series logic analysis system

To use the emulation probe as an emulation module in a 16700-series logic analysis system you must have installed an E5901B emulation module and you must connect the emulation probe to the emulation module using the module/probe interconnect cable. In addition, the emulation probe must be connected to the logic analysis system using a LAN.

- Check that the emulation probe and the logic analysis system are on the LAN.

If you are using a site LAN you should be able to ping both the logic analysis system and the emulation probe.

If you are using a point-to-point LAN connection you must use a special crossover LAN cable, such as the one supplied with the emulation module.

The telnet window of the logic analysis system should be able to communicate with the emulation probe. This window can be found by selecting the "System Admin" icon in the main system window.

- Check that the emulation probe is connected to the emulation module with the module/probe interconnect cable.

If this cable is connected, you should be able to display the firmware version from the "Update Firmware" window.

- Check that you have the proper processor support package installed.

You can check this by selecting the System Admin icon in the main system window, then looking at the list of software packages installed.

- Test the emulation module. See page 155.
- Test the emulation probe. See page 156.
- Try using the Setup Assistant to configure your measurement setup.

Step 5: Check your debugger connection

If you are using a debugger, try connecting to the emulation probe.

If you have problems using the emulation probe with a debugger

Most problems are associated with not having the emulation probe and target properly configured or initialized.

Some debuggers have an initialization file that needs to be properly defined before a debugger can connect to the emulation probe.

- Make sure the PC or workstation where the debugger is running can ping the emulation probe. (See "To verify LAN communications using ping" on page 51.)

General Troubleshooting

- Initialize the emulation probe and target so that the debugger can connect. Refer to your debugger manual for proper initialization.
- Refer to your debugger manual for proper operation.

If you need to obtain help

If, after following the troubleshooting steps and looking through the other sections in this chapter, the emulation probe still is not working:

- 1** Write down the target processor version, the emulation probe firmware version, and the type of emulation probe (E5900A or E5900B). See page 138 for instructions on how to display the emulation probe firmware version.
- 2** Call your nearest Agilent Technologies sales or service office.

To locate a sales or service office near you, go to <http://www.tm.agilent.com> and select [Contact Us](#).

Status Lights

Emulation Probe Target Status Lights

The emulation probe uses status lights to communicate various modes and error conditions.

The following table gives more information about the meaning of the power and target status lights.

○ = LED is off

● = LED is on

Power/Target Status Lights

Pwr/Target LEDs	Meaning
○ RST ○DBG ○ RUN	No target system power, or emulation probe is not connected to the target system
● RST ○DBG ○RUN	Target system is in a reset state
○RST ● DBG ○RUN	The target processor is in Debug Mode
○RST ○DBG ● RUN	The target processor is executing user code
○RST ● DBG ● RUN	Only boot firmware is good (other firmware has been corrupted)
● RST ● DBG ● RUN	The emulation probe can no longer control the target. Reset the target, then initialize the emulation probe.

Status Lights

Emulation Probe LAN Status Lights

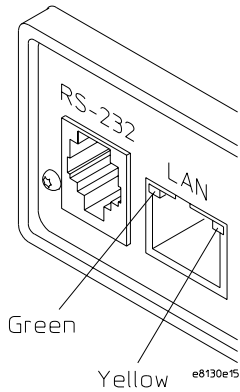

The yellow LED, on the right side of the connector, indicates LAN activity (receive or transmit).

The green LED, on the left side of the connector, is lit when the LAN interface is operating in 100Base-Tx mode.

Emulation Probe Power On Light

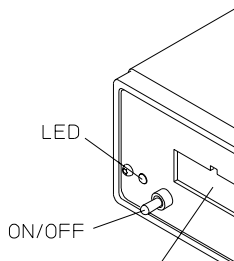

The green LED, to the left of the power switch, is lit when the emulation probe is connected to a power source and the power switch is on.

Using the Emulation Probe Command Line Interface

The emulation probe has some built-in commands (also called the “terminal interface”) which you can use for troubleshooting. See page 88 for instructions on using the command line interface.

To list the emulation probe commands

To list the emulation probe command line mode commands enter:

```
? *
```

To get help on an individual command enter

```
? <command name>
```

Examples

? cf	Help on configuration questions
? cf speed	Help on configuration speed question

To use the built-in commands

Here are a few commonly used built-in commands:

Overview of Useful built-in commands

b	Break—go into the background monitor state
cf	Configuration—read or write configuration options
help	Help—display online help for built-in commands
init	Initialize— <code>init -c</code> re-initializes everything in the emulation probe except for the LAN software and configuration settings
lan	configure LAN address
m	Memory—read or write memory
reg	Register—read or write a register
mtest	Memory test—test target memory system
r	Run—start running user code
rep	Repeat—repeat a command or group of commands
rst	Reset—reset the target processor
s	Step—do a low-level single step
ver	Version—display the product number and firmware version of the emulation probe

Use `help command_name` to see the command syntax. For example, enter `help m` to get help on the memory command.

Examples of built-in commands

Reset, break and run commands

```
rst    To reset the target
b      To break(stop) the target into debug mode
        (Background)
r      To run the target
r 100 To run the target from an address
r rst  To run the target from reset
```

Register commands

```
reg          Read all of the registers
reg pc      Read the program counter
reg pc r0 r1 Read multiple registers
reg pc=200  To Set the pc to 0x200
```

All register and memory values are entered as hexadecimal values and should not be entered with the leading "0x". Use values like "200", NOT "0x200".

Memory commands

```
m 0..ff      Display memory from 0 through ff
m -d1 0..ff=0,1,2,3 Write 0,1,2,3 repetitively
               through the memory 0 to ff
```

Memory test commands

```
mtest bp -a1 0..ff=55      Basic pattern test
                             byte access
mtest bp -a4 0..ff=55555555 Basic pattern test
                             4-byte access
? mtest                    Additional test
                             information
```

To write a NOP loop into memory

NOTE:

This example is specific to the PowerPC processor family. Please adapt this example for the processor type you are using.

```
b          To stop target if not
           already stopped
reg msr=40  Set machine state
reg hid0=c00 Disable caches
m -d4 2000=60000000,4bfffffc To write NOP loop
                               into memory
reg pc=2000 To Set the pc
```

To step the program

```
s          Step one instruction
PC = 00002004 Shows the new location of the PC
s 10      Step ten instructions
? s       Additional information on stepping
? ss      Additional information on source
           stepping
```

To run the simple NOP program

```
r 2000    Run from address 2000
b         To stop the program
reg pc    To see the location of the PC register
r         To continue running the program
```

To set a software breakpoint (Memory trap replacement breakpoints)

```
bc -e swbp Enable Software Breakpoints
bp -p 2004  To set a Software Breakpoint at address
           2004
bp         To review the breakpoints that are set
r         To run the program and hit the software
           breakpoint !ASYNC_STAT 603! Software
           breakpoint: 00002004
bp -r *    To remove all software breakpoints
```

To set a hardware breakpoint (On processor breakpoint registers)

(Use this type of breakpoint when debugging ROM)

```
bc -d swbp      Disable software breakpoints
bc -e hwbp      Enable hardware breakpoints
bc -h -p 2004   To set a hardware breakpoint at
                address 2004
r               To run the program and hit the hardware
                breakpoint !ASYNC_STAT 601! Hardware
                breakpoint: 00002004
bp -h -r *      To remove all hardware breakpoints
? bp           To see additional bp capabilities
                (Hardware Breakpoints can be set on
                memory transactions also)
```

To use command line editing

```
<cntrl>-r      To recall last command(s) backward
<cntrl>-b      To recall last command(s) forward
? cl           To show you how to do it
cl -e          To enable command line editing
<ESC>         To enter command line editing mode
```

To build scripts

To build scripts, get the script utility from our web site

<http://www.cos.agilent.com/probe>.

Download the script utility. This is a unsupported utility but it will work for most scripts that you may want to build. It is unsupported in that if you find a defect with it we may choose not to fix the defect. The source code of the utility is also available. The emulload utility also has the ability to download ELF, COFF, IEEE695 and S-record files.

To flash memory

This is best left to a debugger interface.

You may also want to use the Emulation Control Interface in the logic analysis system to flash target ROM.

In addition we provide some information at our Web site on how to build scripts to flash parts. Go to **<http://www.cos.agilent.com/probe>** and choose [Flashing Target ROM](#).

To display the emulation probe firmware version

```
ver
```

See Also

Use the **help** command for more information on these and other commands. Note that some of commands listed in the help screens are generic commands for Agilent emulation probes and may not be available for your product.

If you are writing your own debugger, contact Agilent Technologies for more information.

Emulation probe command line prompts

The prompt indicates the status of the emulation probe:

Emulation probe prompts

U>	Running user program
M>	Running in background monitor
p>	No target power
R>	Emulation reset
r>	Target reset
c>	Checkstop
?>	Unknown state
->	Firmware is not properly communicating with the target (Try running " init -p " immediately to correct this condition)
\$	\$ with any prompt indicates to a telnet user that the emulator is in use by a debugger or a logic analysis system's Emulation Control Interface

Use **help command_name** to see the command syntax. For example, enter **? m** or **help m** to get help on the memory command.

Configuration commands

The following commands are useful to determine whether your emulation probe is working properly.

<code>cf proc</code>	Read the current processor choice
<code>? cf proc</code>	Show all choices for processor choice
<code>cf proc=mpc8240</code>	Set the processor to type Motorola MPC8240
<code>cf proc=mpc8260</code>	Set the processor to type Motorola MPC8260
<code>cf speed</code>	Read the speed setting
<code>cf speed=4M</code>	Set the JTAG communication speed to 4 MHz
<code>cf speed=16M</code>	Set the JTAG communication speed to 16 MHz
<code>? mtest</code>	Show available memory tests
<code>mtest w1 -a1 0..100</code>	Do a walking ones memory test from memory location 0 to 100

Problems with the Target System

What to check first

Verify that the cf options are correct for your target.

- 1 Try some basic built-in commands using the Command Line window or a telnet connection:

```
U>rst
U>
```

This should reset the target and display a "U>" prompt if 'cf reset=run'.

```
U>rst
M>
```

This should reset the target and display an "M>" prompt if 'cf reset=stop'.

```
M>vads
```

If you are using the Motorola MPC8260 VADS evaluation target, this command will configure the memory system.

```
M>m 0..=abcd1234
M>m 0..
00000000 abcd1234 abcd1234 abcd1234 abcd1234
00000010 abcd1234 abcd1234 abcd1234 abcd1234
00000020 abcd1234 abcd1234 abcd1234 abcd1234
00000030 abcd1234 abcd1234 abcd1234 abcd1234
00000040 abcd1234 abcd1234 abcd1234 abcd1234
00000050 abcd1234 abcd1234 abcd1234 abcd1234
00000060 abcd1234 abcd1234 abcd1234 abcd1234
00000070 abcd1234 abcd1234 abcd1234 abcd1234
```

```
M>
```

This should display memory values starting at address 0.

```
M>s
```

This should execute one instruction at the current program counter.

If any of these commands don't work, there may be a problem with the design of your target system, a problem with the revision of the processor you are using, or a problem with the configuration of the emulation module.

- 2 Check that the emulation module firmware matches your processor. To do this, enter:

```
M>ver
```

To check the debug port connector signals

- Check for the following logic levels on the target debug port.

Levels with the emulation module not connected:

Header Pin	Signal Name	Level
3	TDI	Low
4	TRST	High/Low (depends on pullup or pulldown.)
6	+POWER	VDD
7	TCK	High
9	TMS	High
11	SRESET	High
13	HRESET	High
15	CHECKSTOP	High
16	GND	Low

Levels with the emulation module connected:

Header Pin	Signal Name	I/O
1	TDO	Toggle with "es" command
3	TDI	Toggle with "es" command
4	TRST	Low pulse with "rst" command
6	+POWER	VDD
7	TCK	10+ MHz clock (default)
9	TMS	Low, pulse with "es" command
11	SRESET	High, pulse low with "rst" command
13	HRESET	High, pulse low with "rst" command
15	CHECKSTOP	High
16	GND	Low

To interpret the initial prompt

The initial prompt can be used to diagnose several common problems. To get the most information from the prompt, follow this procedure:

- 1 Connect the emulation module to your target system.
- 2 Set the default configuration settings. Enter:

```
M>cf default
```

If you are using the MPC8240, also enter:

```
M>cf proc=MPC8240
```

You can enter this command at any prompt. The emulation module will respond with the same information as printed by the “ver” command.

If the response is “!ERROR 905! Driver firmware is incompatible with ID of attached device”

Make sure the target interface module is connected to the cable of the emulation module, then try the “init -c” command again.

If the initial prompt is “p>”

Check pin 6 on header, 3.3V (VDD).

If the initial prompt is “M>”

The processor entered debug mode without the help of the emulation module. Is another debugger connected?

If the initial prompt is “c>”

Processor is checkstopped. Something caused a machine exception before the emulation module connected or CHECKSTOP is being pulled or held low.

If the initial prompt is “?>”

A bad status code (0xXX) was received from the processor. Valid status is 0x01 or 0x05. Any other status indicates a bad scan of the instruction register. Check TCK, TDO, TDI, TMS, and TRST signals. Check the firmware revision.

If the initial prompt is “U>”

Processor is running and the emulation module is scanning the instruction register correctly.

Now you can do some more tests:

3 Enter the reset command:

```
U>rst
U>
```

If the prompt after rst is "?>"

A bad status code (0xXX) was received from the processor. Valid status is 0x01, any other status indicates bad scan of the instruction register or failure of the reset signals. Verify TCK, TDO, TDI, TMS, and $\overline{\text{TRST}}$ are all changing state on an $\overline{\text{HRESET}}$.

If the rst command fails

Set "cf reset=stop" (no external bus cycles used in this mode), then enter the "rst" command again:

```
*>cf reset=stop
*>rst
M>
```

You can enter these commands at any prompt, shown here as "*>".

- If the prompt is "M>" with no error messages, all scans worked. We have control as long as we don't try to run code.
- If an error message is displayed, verify that $\overline{\text{HRESET}}$ and $\overline{\text{SRESET}}$ are being driven.
- If the prompt is "c>", there was bad scanning of the data scan chain. Check processor mask revision.
- If the prompt is "U>", the processor failed to stop soft or hard. Check reset lines, mask revision, processor type and firmware version.

If the prompt after rst is "U>"

The $\overline{\text{HRESET}}$ and $\overline{\text{SRESET}}$ lines are working.

Problems with the Target System

Continue with more tests:

4 Enter the break command:

```
U>b  
M>
```

If the prompt after b is "M>"
with error messages

If you see: "!ERROR 145! Unable to soft stop - freezing the processor clocks" the processor is hard stopped. Check the mask revision, processor type, and firmware version. If all of these look good, the target may not be terminating cycles (pending external bus cycles). Successive run ("r") and step ("s") commands will fail. The processor may have fetched an invalid instruction.

Check the value of the PC (IAR):

```
M>reg PC  
reg PC= xxxxxxxx  
M>
```

If the value is fff00100, the processor had a problem accessing the boot ROM and crashed during boot.

Processor and/or board level reset is required to recover from "freezing processor clocks" -- register and memory commands should still work.

If the prompt after b is "M>"
with no error messages

Everything is still working correctly.

If you can get to the "M>" prompt, continue with more tests:

5 At the "M>" prompt, check register and memory access:

```
M>reg r0=12345678  
M>reg r0  
reg r0=12345678  
M>
```

If the returned value is equal to the written value, then the VDD level of the

chip is probably correct.

Now enter:

```
M>m -d4 -a4 0=11111111,22222222,33333333,44444444
M>m -d4 -a4 0..
  00000000 11111111 22222222 33333333 44444444
  00000010 00000000 00000000 00000000 00000000
  00000020 00000000 00000000 00000000 00000000
  00000030 00000000 00000000 00000000 00000000
  00000040 00000000 00000000 00000000 00000000
  00000050 00000000 00000000 00000000 00000000
  00000060 00000000 00000000 00000000 00000000
  00000070 00000000 00000000 00000000 00000000
```

If the target memory system is configured, this should write abcd1234 to memory starting at 0 and then read back the same values.

M>

- Returned value is equal to the written value implies that memory is working.
- Returned value is not equal to the written value implies that memory control may not be initialized. Try to initialize by:

```
M>cf reset=run;rst;w 5
  #waiting for 5 seconds...
```

U>b

M>

- Repeat above memory test.
- Check memory access size using the mo command:

M>mo

- Check access size matches target memory -a0. The default access size -a0 is the 64-bit access.

M>mo -d4 -a0

- Repeat above memory test.

Problems with the Target System

6 At the "M>" prompt, check the processor's revision level:

For example:

```
M> reg pvr
    reg pvr=xxxxxxxx
M>
```

At the time of this release both 8240 and 8260 will return a value of 00910101 or 00810101.

If you see memory-related problems

1 Enter:

```
M>m -d4 -a4 0=11111111,22222222,33333333,44444444
M>m -d4 -a4 0..
    00000000 11111111 02222222 33333333 44444444
    00000010 00000000 00000000 00000000 00000000
    00000020 00000000 00000000 00000000 00000000
    00000030 00000000 00000000 00000000 00000000
    00000040 00000000 00000000 00000000 00000000
    00000050 00000000 00000000 00000000 00000000
    00000060 00000000 00000000 00000000 00000000
    00000070 00000000 00000000 00000000 00000000
M>
```

- RAM must be at address 0.
- Read value not equal to the written value implies that the memory controller is not setup correctly.

2 Hand load a small program:

```
start 1000=38210001   addi r1,r1,1   #Increment r1 by 1
      1004=60000000   nop
      1008=60000000   nop
      100c=4bffffff4  b   start     #Loop back to start
```

The opcode 0x4bffffff4 is a branch to a relative offset, so this program can be placed at any start address.

```
M>reg r1=0
M>m -a4 -d4 1000=38210001,60000000,60000000,4bffffff4
```

Verify that stepping the program will increment the register.

```
M>s
M>reg r1
M>reg r1=00000001
```

Run the program and check the value of reg r1.

```
M>r 1000
U>reg r1
   reg r1=00034567 # or some number
U>reg r1
   reg r1=00102333 # or some number
U>
```

This program will loop forever, incrementing r1. This is a good test program to load once a memory system is up to make sure the microprocessor can run code from memory.

If the processor spontaneously runs after break

Running from reset may cause problems. To ensure proper operation clear the software watchdog enable bit in the SYPCR register.

If you reset to monitor (set cf reset=stop, see page 69) the problem won't happen because the emulation probe writes to the SYPCR and clears the software watchdog enable bit.

If you see the "!ASYNC_STAT 173!" error message

If after a break, the following error arises:

```
!ASYNC_STAT 173! MSR.RI bit not set - Break may not be recoverable
```

This indicates that the MSR.RI bit is not set, implying that a non-maskable break was needed, and the interrupt may not be recoverable. If this occurs while breaking out of regular code, then the MSR.RI bit was not set in the boot code. This can be fixed by 'ORing' in 0x00000002 into the SRR1 register and resuming the run.

If you see the "!ERROR 145!" error message

If the following error arises:

```
!ERROR 145! Unable to soft stop - freezing the processor clocks
```

The processor is in an unstable state and should be reset via a hard reset or a power-on reset. The 'rst' command may not be able to bring the processor into a known state.

Other error messages

The following is a list of unique error messages that may be encountered for this product.

- !ERROR 644! Could not update IMMR register

Check the value of the cf_rstimmr configuration item. See page 79.

- !ERROR 644! cf_immr does not match actual IMMR

Code executed on the target system may have changed the value of the IMMR.

- !ERROR 644! Unable to modify SYPCR register

Check the value of the cf_rstimmr configuration item. See page 79.

- !ERROR 644! Register <reg> does not match its shadow segment register

To synchronize the segment register with its shadow register, write a value to the segment register. For example: m>reg sr0=0.

Problems with the LAN Interface

If you cannot verify LAN communication

If you cannot verify connection using the procedure in "To verify LAN communication", or if commands are not accepted by the emulation probe:

- ❑ Make sure that you have connected the emulation probe to the proper power source and that the power light is lit.
- ❑ Make sure that you wait for the power-on self test to complete before connecting.
- ❑ Check that the Emulation Control Interface or debugger was configured with the correct LAN address. If the emulation probe is on a different subnet than the host computer, check that the gateway address is correct.
- ❑ Make sure that the emulation probe's IP address is set up correctly. To do this, connect the emulation probe to a terminal or terminal emulator and enter the **lan** command. (See "To configure LAN parameters using a serial connection" on page 42.)
- ❑ Make sure that the gateway address is set up correctly. The default gateway address of 0.0.0.0 does not allow the emulation probe to communicate with computers on other subnets.
- ❑ If you have just changed the IP address of the emulation probe, leave the emulation probe powered on and connected to the LAN for a few minutes, then try again. Some hubs, routers, and hosts maintain tables of IP addresses and link-level addresses. It may take a while for these tables to be updated.
- ❑ Make sure that the proper LAN cable is connected.
 - Use a Category 5 cable if your connection is running at 100 Mbps (100BASE-TX).
 - For a point-to-point connection, use a crossover cable.
 - For a LAN connection, use a regular LAN cable, not a crossover cable (the cable supplied with the emulation module, part number 5061-7342, is a crossover cable).

- ❑ Watch the LAN LEDs to see whether the emulation probe is seeing LAN activity. The LEDs are described on page 132. Refer to your LAN documentation for information on testing connectivity.
- ❑ It's also possible for there to be a problem with the emulation probe firmware while the LAN interface is still up and running. In this case, you must reboot the emulation probe by turning the emulation probe power switch off then on again.

If you have LAN connection problems

- ❑ Verify the IP address and gateway mask of the emulation probe. To do this, connect the emulation probe to a terminal or terminal emulator and enter the **lan** command. (See “To configure LAN parameters using a serial connection” on page 42.)

If it takes a long time to connect to the network

- ❑ Check the subnet masks on the other LAN devices connected to your network. All of the devices should be configured to use the same subnet mask.

Subnet mask error messages do not indicate a major problem. You can continue using the emulation probe.

If there are many subnet masks in use on the local subnet, the logic analysis system may take a very long time to connect to the network after it is turned on.

If you have problems setting the LAN parameters using a logic analysis system

- ❑ If the E5900B emulation probe is not connected to an E5901B emulation module, then make sure the emulation probe is on the same subnet as the logic analysis system during initial setup; otherwise, probe LAN address

Problems with the LAN Interface

setup will fail. After initial setup, you can modify the emulation probe's LAN parameters using the Emulation Control Interface before moving the probe to a different subnet.

- ❑ Another thing that will cause emulation probe LAN address setup to fail is a BOOTP daemon, running elsewhere on your network, that is configured to respond to the link-level address of the emulation probe.

Problems with the Serial Interface

If you cannot verify RS-232 communication

If the emulation probe prompt does not appear in the terminal emulator window:

- Make sure that you have connected the emulation probe to the proper power source and that the power switch is on.
- Make sure that you have properly configured the data communications parameters on the host computer.
- Verify that you are using the correct cable. Use the cable and adapter which are supplied with the emulation probe.

If you have RS-232 connection problems with the MS Windows Terminal program

- Use the "HyperTerminal" program (usually found in the Accessories windows program group) and set up the "Communications..." settings as follows:
 - Baud Rate: 9600
 - Data Bits: 8
 - Parity: None
 - Stop Bits: 1
 - Flow Control: None

When you are connected, hit the Enter key. You should get a prompt back.

- If you still don't get a prompt, make sure the serial cable is connected to the correct port on your PC.
- Make sure you are using the serial cable which was supplied with the emulation probe.

With certain RS-232 cards, connecting to an RS-232 port where the emulation

Problems with the Serial Interface

probe is turned off (or is not connected) will hang the PC. The only way to get control back is to reboot the PC. Therefore, we recommend that you always turn on the emulation probe before attempting to connect via RS-232.

Problems with the Emulation Module

Occasionally you may suspect a hardware problem with the emulation module. The procedure in this section describes how to test the emulation module hardware, and if a problem is found, how to repair or replace the broken component.

This procedure tests the hardware within the logic analysis system—the emulation module and its connection to the logic analysis system. To test the emulation probe, see page 156.

To test the emulation module

- 1** End any Emulation Control Interface or debugger sessions.
- 2** Disconnect the emulation probe from the target system.
- 3** In the system window, select the **System Admin** icon.
- 4** Select the **Admin** tab.
- 5** Select **Self-Test...**
- 6** Read the Question dialog and select **Yes** if you wish to run the self tests.
- 7** Select the **Master Frame** tab.
- 8** Select the **E5901B Emulation Module**.
- 9** Select **Test All**.
- 10** When you are finished running self tests, select **Quit**. Then restart your session from the Session Manager window.

Problems with the Emulation Probe

To run the emulation probe performance verification tests

In addition to the powerup tests, there are several additional performance verification (PV) tests available.

These tests can be performed through a 16700-series logic analysis system or via a serial or telnet connection.

Before running probe performance verification:

- Leave the emulation probe connected to the LAN and to the power supply or module/probe interconnect cable.
- Leave the target board adapter installed inside the emulation probe.
- End any Emulation Control Interface or debugger sessions.
- Disconnect the target cable from the target system. (Power off the emulation probe while you do this.)
- Connect an SMB cable (such as Agilent 16532-61601) from the "Break In" connector to the "Trigger Out" connector on the front panel of the emulation probe. (If you aren't concerned about these signals, you may omit this step and ignore any related test failures.)

To run the performance verification tests using the logic analysis system

- 1** End any Emulation Control Interface or debugger sessions.
- 2** Turn off the emulation probe and disconnect the emulation probe from your target system, then turn the emulation probe on again.

CAUTION:

Disconnect the emulation probe from your target system before running the Performance Verification tests. Running the Target Board Adapter Feedback Test (which is part of the **pv** test) with the target system connected can damage components on the target system.

3 In the system window, select the emulation probe icon then select **Performance Verification**.

4 Select **Start PV**.

The results will appear on screen.

To run complete performance verification tests using a serial or telnet connection

1 Connect an SMB cable (such as Agilent 16532-61601) between BREAK IN and TRIGGER OUT on the front panel of the emulation probe.

2 Disconnect the probe/module interconnect cable.

3 Turn off the emulation probe and disconnect the emulation probe from your target system, then turn the emulation probe on again.

CAUTION:

Disconnect the emulation probe from your target system before running the Performance Verification tests. Running the Target Board Adapter Feedback Test (which is part of the **pv** test) with the target system connected can damage components on the target system.

4 Connect the emulation probe to your PC or workstation using a serial or LAN connection, as described in “Connecting the Emulation Probe to a LAN” on page 37.

5 Use a **telnet** or a terminal emulator to connect to the emulation probe.

6 Enter the **pv 1** command.

See Also

Options available for the **pv** command are explained in the help screen

Problems with the Emulation Probe

displayed by typing `help pv` or `? pv` at the prompt.

Examples

Here are some examples of ways to use the `pv` command.

To execute all of the tests one time:

```
pv 1
```

The results on a good system, with the trigger out and break in SMBs connected, should similar to the following.

```
U>pv 1
```

```
Testing: HPE8130A Series Emulation System
Test  1: Powerup PV Results                Passed!
Test  2: Emulation Module Port Feedback Test  Passed!
Test  3: Run Control FPGA Test              Passed!
Test  4: Run Control Clock Test             Passed!
Test  5: Break In and Trigger Out SMB Feedback Test  Passed!
Test  6: Target Board Adapter Feedback Test (FACTORY ONLY) Not Executed
FAILED Number of tests: 1                Number of failures: 0
```

```
Copyright (c) Agilent Technologies, Inc. 1999
All Rights Reserved.  Reproduction, adaptation, or translation without
prior
written permission is prohibited, except as allowed under copyright laws.
```

```
HPE8130A Series Emulation System
Version:  A.01.00 Dec 30 1999
Location:  Generics
```

```
HP E3454A PowerPC 700 JTAG Emulator
Version:  A.05.00 Oct 26 1999
```

```
R>
```

The product numbers and version information will be different for your emulation probe. The product numbers displayed are for the various pieces of firmware and will be different from the product number you used to order the product.

To execute test 2 with maximum debug output repeatedly until a Ctrl-c is entered:

```
pv -t2 -v9 0
```

If a performance verification test fails

There are some things you can do if a failure is found on one of the tests. Details of the failure can be obtained through using a `-v` value (“verbose level”) of 9.

If there are random problems

Occasionally development systems for the PowerPC using the Agilent emulation probe can experience erratic behavior, or random target connection and operation errors or failures. Two major causes for these problems are:

- Crosstalk between the JTAG signals on the cable between the emulation probe and the target.
- Noise from the external fields being coupled into the target connection cable. Major external fields that can affect this connection include the startup and shutdown of nearby fluorescent lamps and CRTs. Universal motors in appliances such as vacuum cleaners and floor buffers can generate significant field impulses.

The following are two potential solutions to the problems mentioned above.

1. Reduce the TCK clock rate. A reduction from 32 MHz to 10 MHz (cf speed = 10 M) can cause up to a 50% reduction in the crosstalk. The most significant side effect is a reduction in download rate. If the increase in download times cannot be tolerated the TCK clock rate can be increased for the duration of the download time, then reduced to gain the increased reliability while debugging.
2. Provide an additional ground path between the emulation probe and the target system. The SMB connections on the front of the emulation probe provide a solid ground connection.

If the particular failure you see is not listed below, contact Agilent Technologies for assistance.

Test 1: Powerup PV Results

Failure of this test indicates a hardware problem with the emulation probe. Contact Agilent Technologies for assistance.

Test 2: Emulation Module Port Feedback Test

Failure of this test indicates a hardware problem with the emulation probe. Contact Agilent Technologies for assistance.

This test exercises the hardware which drives the connection to the emulation

Problems with the Emulation Probe

module. It does not test the module/probe interconnect cable.

The test is not executed if the emulation probe is connected to an emulation module.

Test 3: Run Control FPGA Test

Test 4: Run Control Clock Test

Failure of these tests indicates a hardware problem with the emulation probe. Contact Agilent Technologies for assistance.

If the emulation probe fails one of these tests, it may have been damaged by electrostatic discharge through the target cable. To prevent such damage in the future, follow standard ESD preventive practices.

Test 5: Break In and Trigger Out SMB Feedback Test

Before returning to Agilent Technologies, check to ensure that you have connected a good cable between the two SMB connectors.

Test 6: Target Board Adapter Feedback Test

Failure of this test indicates a hardware problem with the emulation probe. Contact Agilent Technologies for assistance.

This test exercises the I/O circuitry. If the test passes, but the emulation probe seems to have trouble communicating with the target system, the problem is probably with the target system.

If this test was not executed, it means that the target board adapter you are using does not support the test.

Returning Parts for Service

The repair strategy for this emulation probe is board replacement.

Exchange assemblies are available when a repairable assembly is returned to Agilent Technologies. These assemblies have been set up on the “Exchange Assembly” program. This lets you exchange a faulty assembly with one that has been repaired, calibrated, and performance verified by the factory. The cost is significantly less than that of a new assembly.

To return a part to Agilent Technologies

- 1** Follow the procedures in this chapter to make sure that the problem is caused by a hardware failure, not by configuration or cabling problems.
- 2** In the U.S., call 1-800-403-0801. Outside the U.S., call your nearest Agilent sales office. Ask them for the address of the nearest service center.

To locate a sales or service office near you, go to <http://www.tm.agilent.com> and select [Contact Us](#).

- 3** Package the part and send it to the Agilent service center.

Keep any parts which you know are working. For example, if only a cable is broken, keep the emulation probe.

- 4** Agilent will repair or replace the part and send it back to you.

The unit returned to you will have the same serial number as the unit you sent to Agilent.

In some parts of the world, on-site repair service is available. Ask an Agilent sales or service representative for details.

To obtain replacement parts

The following table lists some parts that may be replaced if they are damaged or lost. Not all parts are shipped with every product. The part numbers are subject to change. Contact your nearest Agilent Technologies sales office for further information.

Exchange assemblies

Part number	Description
E3453-69501	Rebuilt PC board assembly (MPC82xx).

Replacement assemblies

Part number	Description
0950-3043	Power supply for emulation probe.
E3494-61604	Ribbon cable - PowerPC 400/600/700, MPC 82xx. (Connects the emulation probe to the target system.)
16700-61608	Expansion cable for emulation module. (Connects the emulation module to the logic analysis system internally.)
E8130-68702	Serial cable and adapter. (Connects the emulation probe to a PC for configuration.)
5061-7342	LAN cross-over cable. (For point-to-point LAN connection from the emulation probe to the logic analysis system.)
E8130-61601	14-pin module/probe interconnect cable. (Connects the emulation module to the emulation probe.)

To clean the instrument

If the instrument requires cleaning:

- 1** Remove power from the instrument.
- 2** Clean the instrument using a soft cloth that has been moistened in a mixture of mild detergent and water.
- 3** Make sure that the instrument is completely dry before reconnecting it to a power source.

Chapter 12: Troubleshooting the Emulation Probe
Returning Parts for Service

Specifications and Characteristics

The following operating characteristics are not specifications, but are typical operating characteristics for the Agilent Technologies E5900B emulation probe and E5901B emulation module.

Operating characteristics

The following operating characteristics are not specifications, but are typical operating characteristics.

Input/Output Electrical Characteristics

Trigger Out SMB Port

With a 50 Ω load, a logic high is ≥ 2.0 V, and a low is ≤ 0.4 V. The output function is selectable (see “To configure the Trigger Out SMB port” on page 74).

Break In SMB Port

Edge-triggered TTL level input, 20 pF, with 4.6 k Ω to ground in parallel. Maximum input: +5 V to -5 V when the emulation probe is powered OFF; +10 V to -5 V when the emulation probe is powered ON. Input function is selectable (see “To configure the Break In SMB port” on page 73).

Communication Ports

Serial Port

RJ12 connector (DB9-to-RJ12 adapter and serial cable included).
RS-232 DCE to 9600 baud, 8-bit, no parity, one stop bit.

IEEE 802.3 Type 10/100Base-TX LAN Port

RJ-45 connector, is compatible with both 10 Mbps (10Base-T) and 100 Mbps (100Base-TX) twisted-pair ethernet LANs.

Power Supply

Input. 100-240 V, 1.0 A, 50/60 Hz, IEC 320 connector.

Output. 12 V, 3.3 A

CAT I (Mains isolated).

E5900B Emulation Probe Characteristics

Microprocessor Compatibility	See page 4 for a list of compatible processors.
-------------------------------------	---

Input Characteristics							
Signal	Symbol	1/3 Vref		1/2 Vref		2/3 Vref	
		Min	Max	Min	Max	Min	Max
TDO	Vih	0.5 Vref	5.1 V	0.65 Vref	5.1 V	0.8 Vref	5.1 V
	Vil	-0.1V	0.2 Vref	-0.1 V	0.35 V	-0.1 V	0.5 Vref
	Ib (Bias)	± 15 uA					
	Rin	4.7 kΩ pullup to Vref					
	Cin	TDO = 75 pF					

Input Characteristics			
Signal	Symbol	Min	Max
Vref	Vin	1.65 V	5.5 V
	Rin	25 kΩ pulldown to ground	
SRESET, HRESET	Rin (inactive)	4.7 kΩ pullup to Vref	
	Rin (active)	12 Ω pulldown to ground	
	Cout		200 pF
	Vin		5.5 V

Output Characteristics Z _o		
Signal	Symbol	Condition
TDI, TCK, TMS, $\overline{\text{TRST}}$ ¹	Voh/Ioh	66 Ω ± 15 Ω to Vref
	Vol/Iol	66 Ω ± 15 Ω to 0.2 V

¹ These signals must not be actively driven by the target system when the debug port is being used.

Output Model

Model of output drive to TDI, TCK, TMS, and TRST.

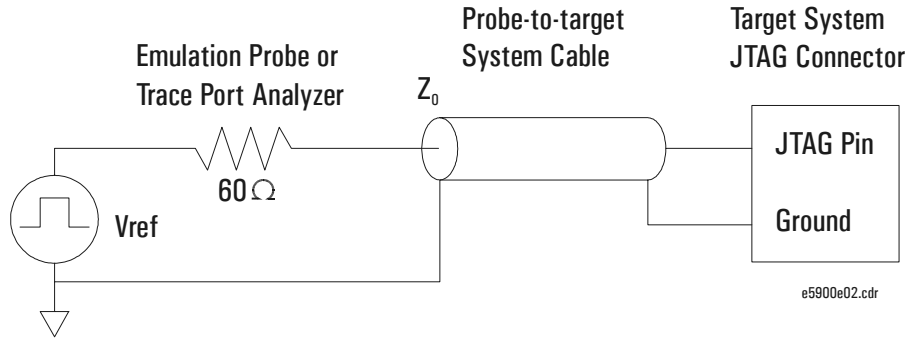

Note: $Z_0 = 66\ \Omega$ in the diagram above.

Environmental Characteristics

Temperature	Operating: +5°C to +40°C (+41°F to +104°F)	Nonoperating: -40°C to +70°C (-40°F to +158 °F)
Altitude	Operating or nonoperating: 4600 m (15 000 ft)	
Relative Humidity	15% to 95% @ 40°C for 24 hrs.	
Pollution Degree	Pollution Degree 2: Normally only dry non-conductive pollution occurs. Occasionally a temporary conductivity caused by condensation may occur.	

For indoor use only.

See Also

See the Declarations of Conformity at the end of this book for EMC, safety, and supplemental information.

Emulation module environmental characteristics

The Agilent E5901B emulation module meets the environmental characteristics of the logic analysis system in which it is installed.

For indoor use only.

Glossary

Analysis Probe A probing solution connected to the target microprocessor. It provides an interface between the signals of the target microprocessor and the inputs of the logic analyzer. Formerly called a “preprocessor.”

Background Debug Monitor Also called Debug Mode, In Background, or In Monitor. The normal processor execution is suspended and the processor waits for commands from the debug port. The debug port commands include the ability to read and write memory, read and write registers, set breakpoints and start the processor running (exit the Background Debug Monitor).

Debug Mode See *Background Debug Monitor*.

Debug Port A hardware interface designed into a microprocessor that allows developers to control microprocessor execution, set breakpoints, and access microprocessor registers or target system memory using a tool like the emulation probe.

Elastomeric Probe Adapter A connector that is fastened on top of a target microprocessor using a retainer and knurled nut. The conductive elastomer on the bottom

of the probe adapter makes contact with pins of the target microprocessor and delivers their signals to connection points on top of the probe adapter.

Emulation Migration Kit The hardware and software required to use an emulation probe with a new processor family.

Emulation Module An emulation module is installed within the mainframe of a logic analysis system. An E5901A emulation module is used with a *target interface module* (TIM) or an analysis probe. An E5901B emulation module is used with an E5900B *emulation probe* and does not use a TIM.

Emulation Probe An emulation probe is a standalone instrument connected via LAN to the mainframe of a logic analyzer or to a host computer. It provides run control within an emulation and analysis test setup. Formerly called a "processor probe" or "software probe."

Emulator An emulation module or an emulation probe.

Extender A part whose only function is to provide connections from one location to another. One or more extenders might be stacked to

Glossary

raise a probe above a target microprocessor to avoid mechanical contact with other components installed close to the target microprocessor. Sometimes called a "connector board."

Flexible Adapter Two connection devices coupled with a flexible cable. Used for connecting probing hardware on the target microprocessor to the analysis probe.

Gateway Address An IP address entered in integer dot notation. The default gateway address is 0.0.0.0, which allows all connections on the local network or subnet. If connections are to be made across networks or subnets, this address must be set to the address of the gateway machine.

General-Purpose Flexible Adapter A cable assembly that connects the signals from an elastomeric probe adapter to an analysis probe. Normally, a male-to-male header or transition board makes the connections from the general-purpose flexible adapter to the analysis probe.

High-Density Adapter Cable A cable assembly that delivers signals from an analysis probe hardware interface to the logic analyzer pod

cables. A high-density adapter cable has a single *MICTOR connector* that is installed into the analysis probe, and two cables that are connected to corresponding odd and even logic analyzer pod cables.

High-Density Termination Adapter Cable Same as a High-Density Adapter Cable, except it has a termination in the *MICTOR connector*.

In Background, In Monitor See *Background Debug Monitor*.

Inverse Assembler Software that displays captured bus activity as assembly language mnemonics. In addition, inverse assemblers may show execution history or decode control busses.

IP address Also called Internet Protocol address or Internet address. A 32-bit network address. It is usually represented as decimal numbers separated by periods; for example, 192.35.12.6.

Jumper Moveable direct electrical connection between two points.

JTAG (OnCE) port See *debug port*.

Label Labels are used to group and

Glossary

identify logic analyzer channels. A label consists of a name and an associated bit or group of bits.

Link-Level Address The unique address of the LAN interface. This value is set at the factory and cannot be changed. The link-level address of a particular piece of equipment is often printed on a label above the LAN connector. An example of a link-level address in hexadecimal: 0800090012AB. Also known as an LLA, Ethernet address, hardware address, physical address, or MAC address.

Mainframe Logic Analyzer A logic analyzer that resides on one or more board assemblies installed in a 16500, 1660-series, or 16600/700-series mainframe.

Male-to-male Header A board assembly that makes point-to-point connections between the female pins of a flexible adapter or transition board and the female pins of an analysis probe.

MICTOR Connector A high-density matched impedance connector manufactured by AMP Corporation. *High-density adapter cables* can be used to connect the logic analyzer to MICTOR connectors on the target system.

Monitor, In See *Background Debug Monitor*.

Pod A collection of logic analyzer channels associated with a single cable and connector.

Preprocessor See *Analysis Probe*.

Preprocessor Interface See *Analysis Probe*.

Probe Adapter See *Elastomeric Probe Adapter*.

Processor Probe See *Emulation Probe*.

Run Control Probe See *Emulation Probe* and *Emulation Module*.

Setup Assistant Wizard software program which guides a user through the process of connecting and configuring a logic analyzer to make measurements on a specific microprocessor. The setup assistant icon is located in the main system window.

Shunt Connector. See *Jumper*.

Solution Historical term for a set of tools for debugging your target system. A solution included probing, inverse assembly, the B4620B Source

Correlation Tool Set, and an emulation module.

Stand-Alone Logic Analyzer A standalone logic analyzer has a predefined set of hardware components which provide a specific set of capabilities. A standalone logic analyzer differs from a mainframe logic analyzer in that it does not offer card slots for installation of additional capabilities, and its specifications are not modified based upon selection from a set of optional hardware boards that may be installed within its frame.

State Analysis A mode of logic analysis in which the logic analyzer is configured to capture data synchronously with a clock signal in the target system.

Subnet Mask A subnet mask blocks out part of an IP address so the networking software can determine whether the destination host is on a local or remote network. It is usually represented as decimal numbers separated by periods; for example, 255.255.255.0.

Symbol Symbols represent patterns and ranges of values found on labeled sets of bits. Two kinds of symbols are available:

1) Object file symbols — Symbols

from your source code, and symbols generated by your compiler. Object file symbols may represent global variables, functions, labels, and source line numbers.

2) User-defined symbols — Symbols you create.

Target Board Adapter A daughter board inside the E5900B emulation probe which customizes the emulation probe for a particular microprocessor family. The target board adapter provides an interface to the ribbon cable which connects to the debug port on the target system.

Target Control Port An 8-bit, TTL port on a logic analysis system that you can use to send signals to your target system. It does not function like a pattern generator or emulation module, but more like a remote control for the target's switches.

Target Interface Module A small circuit board which connects the 50-pin cable from an E5901A emulation module or E5900A emulation probe to signals from the debug port on a target system. Not used with the E5900B emulation probe.

TIM See *Target Interface Module*.

Timing Analysis A mode of logic analysis in which the logic analyzer is

Glossary

configured to capture data at a rate determined by an internal sample rate clock, asynchronous to signals in the target system.

Transition Board A board assembly that obtains signals connected to one side and rearranges them in a different order for delivery at the other side of the board.

Trigger Specification A set of conditions that must be true before the instrument triggers. See the printed or online documentation of your logic analyzer for details.

1/4-Flexible Adapter An adapter that obtains one-quarter of the signals from an elastomeric probe adapter (one side of a target microprocessor) and makes them available for probing.

Numerics

32-bit mode, 79

A

address pattern test, 102

address translation, 71

address, IP, 41

analysis probe

definition, 171

processors supported, 4

product numbers, 4

assistant

See setup assistant

!ASYNC_STAT 173! MSR.RI bit not

set - Break may not be

recoverable, 148

ASYNC_STAT 173, 148

automatic allocation, 46

B

background debug monitor, 171

base address configuration, 79

basic pattern test, 99

BDM port

See debug port

BNC

break in, 73

trigger out, 74

boot ROM, 144

BOOTP request, 45, 46

Break In SMB, 73

Break In SMB port, 167

built-in commands, 140

LAN configuration, 44

list of commands, 134

C

cable

emulation probe, 61

module/probe interconnect, 35

point-to-point LAN, 39

power, 22

serial, 42

cable board, 20

See target board adapter

cache disable, 80

caches

enabling and disabling, 80

CD-ROM, installing software from,

56

cf rrt, 75

CHECKSTOP signal, 141, 142

cleaning, 163

cleaning the instrument, 183

clocks

TCK speed, 67

command line interface, 88, 133,

140

logic analysis system, 89

commands, built-in, 134

communication ports, 167

configuration

emulation module, 63

configuration commands, 139

configuration files

installing, 53

connection

emulation module, 59

host workstation, 37

power, 22

problems, LAN, 150

problems, RS-232, 153

sequence, 23

connector

10BASE-T, 37

debug port, 28

JTAG, 26

JTAG, designing, 28

connector board, 171

connector, serial, 167

crosstalk, 159

D

data scan chain, 143

DBG light, 131

debug mode, 142, 171

debug port, 171

connecting to, 61

connector signals, 141

definition, 171

debugger, 81, 142

delays, configuring, 76, 77

design considerations, 25

development port

See debug port

DHCP, 45

dynamic allocation, 46

E

E8130A product number, 158

effective addresses, 71

elastomeric probe adapter

definition, 171

electrical characteristics, 168

EMC, 170

emulation migration

definition, 171

See also migration

- emulation module
 - connecting, 59, 61
 - connecting to probe, 35
 - definition, 171
 - description of, 3
 - installing, 31
 - product numbers, 4
- emulation probe
 - definition, 171
- emulation solution
 - definition, 173
- environmental characteristics, 170
- equipment required
 - emulation module, 18
- equipment supplied
 - emulation migration, 20
 - emulation module, 18
 - ordering information, 4
 - overview, 4
- !ERROR 145! Unable to soft stop - freezing the processor clocks, 144
- ERROR 145, 148
- ERROR 905, 142
- error messages, 149
- ethernet address, 44
- extender, 171

- F**
- files
 - loading vs. installing, 54
- firmware
 - revision, 142
 - updating, 111
 - version, 113, 114, 143, 144
- flexible adapter
 - definition, 172
- flowchart, setup, 15
- freezing processor clocks, 144

- G**
- gateway address, 44, 150
 - definition, 172
- general-purpose flexible adapter
 - definition, 172
- GND line, 141

- H**
- HIDO bits, 80
- high-density adapter cable
 - definition, 172
- high-density termination adapter
 - definition, 172
- host computer
 - connecting to, 37
- HRESET signal, 141, 143
- HyperTerminal (MS Windows program), 153

- I**
- IEEE 802.3, 37
- IMMR register, 79
- information sources, 24
- initial prompt, 142
- input/output electrical
 - characteristics, 167
- installation, software, 53
- instruction register, 142, 143
- instrument, cleaning the, 183
- interconnect cable
 - See cable, module/probe interconnect
- internet address, 41
- invalid instruction, 144
- inverse assembler
 - definition, 172
- IP address, 41, 44, 46, 150
 - debugger connection, 84
 - definition, 172

- J**
- JTAG
 - acronym, 16
 - designing connector, 28
 - noise, 159
- JTAG port
 - connections, 28
- jumper, definition, 172

- L**
- labels
 - definition, 172
- LAN
 - connection problems, 150
 - interface, 37
- lan command, 44
- LAN parameters, 46
 - debugger, 84
 - setting with DHCP, 45
 - setting with emulation module, 48
 - setting with serial connection, 44
 - verifying, 45
 - ways to set, 38
- LAN port, 167
- LEDs, 131
- lights, 131
- link-level address, 46
 - definition, 173
 - displaying, 44
 - location of, 45
- loading configurations
 - vs. installing, 53

- M**
- mainframe logic analyzer
 - definition, 173
- male-to-male header
 - definition, 173
- manual allocation, 46

-
- mask
 revision, 143, 144
 subnet, 151
- memory
 configuring delays, 76, 77
 target, testing, 93
- memory mapped registers, 79
- memory test, 93
 address pattern, 102
 basic pattern, 99
 list of tests, 97
 oscilloscope read, 108
 oscilloscope write, 109
 procedure, 98
 rotate pattern, 104
 walking ones, 106
 walking zeroes, 107
- memory-related problems, 146
- microprocessors supported, 4
- MICTOR connector, definition, 173
- migration
 installing, 117
- minimum equipment, 16
- MMU, 71
- model, output, 169
- module/probe interconnect cable,
 35
- monitor, background debug, 171
- MPC8240 processor type, 65
- MPC8255 processor type, 65
- MPC8260 processor type, 65
- MSR.RI bit, 148
- N**
- noise, reducing, 26
- non-maskable break, 148
- O**
- oscilloscope read test, 108
- oscilloscope write test, 109
- output model, 169
- P**
- parity, support, 26
- PC
 connecting to, 37
- pending external bus cycles, 144
- performance verification tests,
 156, 157
- performance, improving, 67
- physical addresses, 71
- ping command, 51, 150
- Pods, logic analyzer, 173
- point-to-point LAN connection, 49
- port number
 changing, 44
 debugger, 84
 default, 41
- POWER line, 141
- power off procedure, 23
- power on procedure, 22
- POWER signal, 29, 78
- power supply, 22, 167
- preprocessor
 See analysis probe
- preprocessor interface
 See *analysis probe*
- problems
 emulation module, 155
 emulation probe, 156
 LAN interface, 150
 memory, 146
 serial interface, 153
- processor family
 changing, 118
- processor mask revision, 143
- processor revision, 140
- processor support package, 56
- processor type, 65, 143, 144
- processors supported, 4
- product numbers, 4, 158
- program counter, 140
- prompt
 ->, 125
 ?, 125
 initial, 142
 list of prompts, 138
- PV, 156
- R**
- real-time runs, 75
- references, 24
- repair
 emulation module, 161
- requirements, 16
- reset lines, 143
- reset operation, 69
- RESET signals, 27
- reset, unexpected, 147
- restrict to real-time runs, 75
- revision level, 146
- revision, processor, 140
- rotate pattern test, 104
- rst command fails, 143
- RST light, 131
- run after break, 147
- run control tool
 See emulation control interface
- RUN light, 131
- running from reset, 147
- S**
- scan chain, 143
- sequence, 23
- serial connection, 42
 cable, 42
 DCE or DTE selection, 153
 number of connections, 153
 problems, 153
 verifying, 43
- serial port, 167
- service ports, 44

service, how to obtain, 161

setup

See configuration

setup assistant, 116

definition, 173

networking disabled, 50

setup flowchart, 15

signals

debug port, 28

slow clock message

troubleshooting, 125

SMB, 159

Break In configuration, 73

software

installing, 53

list of installed, 57

software watchdog, 147

solution

definition, 173

specifications

characteristics, 165

speed

improving, 67

SRESET signal, 141, 143

SRR1 register, 148

standalone configuration

See point-to-point connection

stand-alone logic analyzer

definition, 174

state analysis, 174

definition, 174

static allocation, 45, 46

status code, 138, 142, 143

status lights, 131

subnet mask, 44, 150, 151

definition, 174

switches

LAN configuration, 44

symbols

definition, 174

SYPGR register, 147

T

target board adapter, 20, 118

definition, 174

target control port, 174

target interface module (TIM)

definition, 174

target system

connecting to, 59

memory tests, 93

TCK clock rate, 159

TCK signal, 67, 141, 142, 143

TCP, 44

TDI signal, 141, 142, 143

TDO signal, 141, 142, 143

telnet, 51, 52, 140, 150

establish connection, 88

temperature environmental

characteristic, 170

temperature specifications, 170

terminal interface, 52

LAN parameters, setting, 44

See also built-in commands

terminating cycles, 144

test program, 147

testing

emulation module, 155

target memory, 93

procedure for, 98

ThinLAN, 38

timing analysis, 174

definition, 174

TMS signal, 141, 142, 143

trace length, 26

transition board

definition, 175

trigger

definition of specification, 175

limitations, 73

trigger out configuration, 74

Trigger Out SMB port, 167

troubleshooting, 125

emulation probe, 123

general, 125

LAN interface, 150

target system, 140

TRST signal, 141, 143

TRST_L signal, 142

U

unexpected run, 147

updating firmware, 112

V

versions, firmware

emulation module, 114

emulation probe, 113

voltage reference, configuring, 78

Vref signal, 29, 78

W

walking ones test, 106

walking zeros test, 107

watchdog timer, 147

web interface, 90

web sites

Agilent logic analyzers, 24

wizard

See setup assistant

workstation

connecting to, 37



Agilent Technologies **DECLARATION OF CONFORMITY**

According to ISO/IEC Guide 22 and CEN/EN 45014

Manufacturer's Name: Agilent Technologies, Inc. / Digital Design PGU

Manufacturer's Address: 1900 Garden of the Gods Road
Colorado Springs, Colorado 80907 USA

Declares, that the product

Product Name: Emulation Probe

Model Number(s): Agilent Technologies E5900B, E5902B

Product Option(s): All options based on the above

is in conformity with:

EMC IEC 61326-1:1997+A1:1998 / EN 61326-1:1997+A1:1998
CISPR 11:1990 / EN 55011:1991—Group 1 Class A^[1]
IEC 61000-4-2:1995+A1:1998 / EN 61000-4-2:1995 (ESD 4kV CD, 8kV AD)
IEC 61000-4-3:1995 / EN 61000-4-3:1995 (3 V/m 80% AM)
IEC 61000-4-4:1995 / EN 61000-4-4:1995 (0.5kV line-line, 1kV line-earth)
IEC 61000-4-6:1996 / EN 61000-4-6:1996 (3V 80% AM, power line)
Australia/New Zealand: AS/NZS 2064.1

Safety IEC 1010-1: 1990+A1:1992+A2:1995 / EN 61010-1: 1994+A2:1995
Canada: CSA-C22.2 No. 1010.1:1992
USA: UL 3111-1:1994

Additional Information:

The product herewith complies with the requirements of the Low Voltage Directive 73/23/EEC and the EMC Directive 89/336/EEC (including 93/68/EEC) and carries the CE marking accordingly (European Union).

^[1]This product was tested in a typical configuration with Agilent Technologies test systems.

Date: 12/30/99

Ken Wyatt / Product Regulations Manager

For further information, please contact your local Agilent Technologies sales office, agent or distributor.

Product Regulations

EMC	IEC 61326-1:1997+A1:1998 / EN 61326-1:1997+A1:1998 CISPR 11:1990 / EN 55011:1991—Group 1 Class A IEC 61000-4-2:1995+A1:1998 / EN 61000-4-2:1995 (ESD 4kV CD, 8kV AD) IEC 61000-4-3:1995 / EN 61000-4-3:1995 (3 V/m 80% AM) IEC 61000-4-4:1995 / EN 61000-4-4:1995 (EFT 0.5kV line-line, 1kV line-earth) IEC 61000-4-6:1996 / EN 61000-4-6:1996 (3V 80% AM, power line) Australia/New Zealand: AS/NZS 2064.1	Performance Criteria D A A A
Safety	IEC 1010-1: 1990+A1:1992+A2:1995 / EN 61010-1: 1994+A2:1995 Canada: CSA-C22.2 No. 1010.1:1992 USA: UL 3111-1:1994 {optional}	

Additional Information:

The product herewith complies with the requirements of the Low Voltage Directive 73/23/EEC and the EMC Directive 89/336/EEC (including 93/68/EEC) and carries the CE marking accordingly (European Union).

Performance Criteria:

A Pass - Normal operation, no effect.

B Pass - Temporary degradation, self recoverable.

C Pass - Temporary degradation, operator intervention required.

D Fail - Not recoverable, component damage.

Note:

Use standard ESD preventive practices while handling and connecting the E5900B to its target to avoid component damage.

Sound Pressure Level N/A

Regulatory Information for Canada

ICES/NMB-001

This ISM device complies with Canadian ICES-001.
Cet appareil ISM est conforme à la norme NMB-001 du Canada.

Regulatory Information for Australia/New Zealand

This ISM device complies with Australian/New Zealand AS/NZS 2064.1

Safety Notices

This apparatus has been designed and tested in accordance with IEC Publication 1010, Safety Requirements for Measuring Apparatus, and has been supplied in a safe condition. This is a Safety Class I instrument (provided with terminal for protective earthing). Before applying power, verify that the correct safety precautions are taken (see the following warnings). In addition, note the external markings on the instrument that are described under "Safety Symbols."

Warnings

- Before turning on the instrument, you must connect the protective earth terminal of the instrument to the protective conductor of the (mains) power cord. The mains plug shall only be inserted in a socket outlet provided with a protective earth contact. You must not negate the protective action by using an extension cord (power cable) without a protective conductor (grounding). Grounding one conductor of a two-conductor outlet is not sufficient protection.
- Only fuses with the required rated current, voltage, and specified type (normal blow, time delay, etc.) should be used. Do not use repaired fuses or short-circuited fuseholders. To do so could cause a shock or fire hazard.
- If you energize this instrument by an auto transformer (for voltage reduction or mains isolation), the common terminal must be connected to the earth terminal of the power source.
- Whenever it is likely that the

ground protection is impaired, you must make the instrument inoperative and secure it against any unintended operation.

- Service instructions are for trained service personnel. To avoid dangerous electric shock, do not perform any service unless qualified to do so. Do not attempt internal service or adjustment unless another person, capable of rendering first aid and resuscitation, is present.
- Do not install substitute parts or perform any unauthorized modification to the instrument.
- Capacitors inside the instrument may retain a charge even if the instrument is disconnected from its source of supply.
- Do not operate the instrument in the presence of flammable gasses or fumes. Operation of any electrical instrument in such an environment constitutes a definite safety hazard.
- Do not use the instrument in a manner not specified by the manufacturer.

To clean the instrument

If the instrument requires cleaning: (1) Remove power from the instrument. (2) Clean the external surfaces of the instrument with a soft cloth dampened with a mixture of mild detergent and water. (3) Make sure that the instrument is completely dry before reconnecting it to a power source.

Safety Symbols



Instruction manual symbol: the product is marked with this symbol when it is necessary for you to refer to the instruction manual in order to protect against damage to the product..



Hazardous voltage symbol.



Earth terminal symbol: Used to indicate a circuit common connected to grounded chassis.

Notices

© Agilent Technologies, Inc.
1994 - 2002

No part of this manual may be reproduced in any form or by any means (including electronic storage and retrieval or translation into a foreign language) without prior agreement and written consent from Agilent Technologies, Inc. as governed by United States and international copyright laws.

Manual Part Number

E3453-97008, October 2002

Print History

E3453-97007, June 2002

E3453-97006, January 2002

E3453-97005, November 2001

E3453-97004, May 2001

E3453-97003, February 2001

E3453-97002, July 2000

E3453-97001, May 2000

E3453-97000, March 1999

Agilent Technologies, Inc.
1900 Garden of the Gods Road
Colorado Springs, CO 80907 USA

Restricted Rights Legend

If software is for use in the performance of a U.S. Government prime contract or subcontract, Software is delivered and licensed as "Commercial computer software" as defined in DFAR 252.227-7014 (June 1995), or as a "commercial item" as defined in FAR 2.101(a) or as "Restricted computer software" as defined in FAR 52.227-19 (June 1987) or any equivalent agency regulation or contract clause. Use, duplication or disclosure of Software is subject to Agilent Technologies' standard commercial license terms, and non-DOD Departments and Agencies of the U.S. Government will receive no greater than Restricted Rights as

defined in FAR 52.227-19(c)(1-2) (June 1987). U.S. Government users will receive no greater than Limited Rights as defined in FAR 52.227-14 (June 1987) or DFAR 252.227-7015 (b)(2) (November 1995), as applicable in any technical data.

Document Warranty

The material contained in this document is provided "as is," and is subject to being changed, without notice, in future editions. Further, to the maximum extent permitted by applicable law, Agilent disclaims all warranties, either express or implied, with regard to this manual and any information contained herein, including but not limited to the implied warranties of merchantability and fitness for a particular purpose. Agilent shall not be liable for errors or for incidental or consequential damages in connection with the furnishing, use, or performance of this document or of any information contained herein. Should Agilent and the user have a separate written agreement with warranty terms covering the material in this document that conflict with these terms, the warranty terms in the separate agreement shall control.

Technology Licenses

The hardware and/or software described in this document are furnished under a license and may be used or copied only in accordance with the terms of such license.

WARNING

A WARNING notice denotes a hazard. It calls attention to an operating procedure, practice, or the like that, if not correctly performed or adhered to, could result in personal injury or death. Do not proceed beyond a WARNING notice until the indicated conditions are fully understood and met.

CAUTION

A CAUTION notice denotes a hazard. It calls attention to an operating procedure, practice, or the like that, if not correctly performed or adhered to, could result in damage to the product or loss of important data. Do not proceed beyond a CAUTION notice until the indicated conditions are fully understood and met.

Trademark Acknowledgments

UNIX is a registered trademark of the Open Group.

Windows, MS Windows, and Windows NT are U.S. registered trademarks of Microsoft Corporation.